

# BIOSAFETY AND BIOSECURITY GUIDELINES FOR HEALTH LABORATORIES IN ETHIOPIA



Second Edition  
September 2022

Ethiopian Public Health Institute



ጤና ሚኒስቴር - ኢትዮጵያ  
MINISTRY OF HEALTH - ETHIOPIA



# BIOSAFETY AND BIOSECURITY GUIDELINES FOR HEALTH LABORATORIES IN ETHIOPIA



Second Edition  
September 2022

Ethiopian Public Health Institute

# I. Foreword

The implementation of laboratory biosafety and biosecurity programs is fundamental and crucial for protecting the health workforce, the community, and the environment from exposures to biological hazards. Past and recent sporadic outbreaks of viral infections, such as Severe Acute Respiratory Syndrome (SARS), Ebola hemorrhagic fever, and influenza, among others, have woken the world up to the risks of biological materials and the need for stringent, risk-proof ways of handling them. The urgent need to establish systems and approaches to reduce the risks of biological agents posing health hazards has been heightened by legitimate fears of future episodes of emerging and re-emerging pandemic viruses that can be more cruel, deadly, and devastating to the public's health than those the world has faced to date. Among other scenarios, the ever-increasing threats from the potential use of dangerous pathogens for malicious purposes are fueling global concern. Addressing these concerns and challenges underpins the key objectives and importance of implementing biosafety and biosecurity programs at all health laboratory settings where a wide variety of potentially hazardous biomaterials are tested, stored, shipped, or received, worked with, or disposed of, thus posing real risks to the health and safety of workers, patients, and other clients, as well as precipitating the danger of transient or long-lasting contamination of the environment.

Over the past few years, the Ethiopian Public Health Institute has made considerable progress in the implementation of laboratory biosafety and biosecurity programs nationwide. However, there are still several outstanding challenges that hinder the comprehensive implementation of the programs to the level of the institute's expectations as amenable with pertinent international standards and recommendations. In order to effectively address the challenges and enhance the implementation of the programs across the national laboratory system. This guidance document was developed to facilitate the practical implementation of major activities and initiatives articulated in the Strategic Plan document across all tiers of the national laboratory system and networks through the concerted efforts of all stakeholders and partners. As such, the guidance document is believed to prove an invaluable tool for understanding the essentials and processes of translating the national strategy into actionable plans towards building a robust, functional and sustainable national laboratory biosafety and biosecurity system.

The first edition of the guidelines, entitled Health and Safety Guidelines for Public Health Laboratories in Ethiopia, was published in 2010. Since then, the document has particularly served as an important resource and guiding tool for the practical implementation of the fundamental principles of biosafety across the Ethiopian health laboratory system including those of the military, private and non-governmental faith-based health institutions. Despite its valuable contribution to the systematic

introduction and improved implementation of basic health laboratory biosafety principles and standards in this country, the guidance document had significant limitations in its overall scope with exclusive focus on biosafety while totally lacking biosecurity component and negligibly little or no details on a framework or structure for systematic and effective risk management based on evidences from regular risk assessments, identification, analysis and evaluations as per the current international standards, recommendations and practices. Although the document adequately addresses the conceptual framework for the implementation of biosecurity principles and requirements in a health laboratory setting, it provides insufficient details on prioritized approaches and organized schemes for seamless programmatic implementations with clearly defined specific roles and responsibilities for all concerned stakeholders and partners

This second edition of the guidelines builds on essential elements adapted from the first one, but with particular emphasis on the comprehensive implementation of biosafety and biosecurity requirements and building the necessary capacity and capability for effective biorisk management at all levels of the national health laboratory system. In line with pertinent international standards, guidance, and recommendations, this latest edition emphasizes the importance of standardized protocol-based risk assessment, identification, analysis, and evaluation as a fundamental core principle and proven approach for the systematic implementation and management of biosafety and biosecurity programs. It provides guidance on benchmarking and implementation of best practices, prudent use of technologies, and analytical approaches to address emerging issues and challenges. Furthermore, the document captures the newest lessons learned and best practices earned from the implementation of biosafety and biosecurity requirements for SARS-CoV2 specimen collection, transportation, testing, and biological waste disposal.

This guidance document was developed in collaboration with all stakeholders and partners and is intended to serve as a comprehensive reference and guiding material for the implementation of biosafety and biosecurity programs in Ethiopia. It is thus believed that all health laboratories, teaching and research institutes handling hazardous biological agents, and other organizations involved in biorisk management will make the best use of the document in establishing and strengthening their biosafety and biosecurity systems and practices. The document will be reviewed and revised based on best practices and lessons learned from actual implementation activities over the next few years, as well as in consideration of evolving biorisk management needs, updated guidance and recommendations from subject matter authoritative international organizations.

On behalf of EPHI, I would like to express my sincere appreciation and heartfelt thanks to all experts and organizations that have contributed to the development of this document and confirm the institute's

commitment to provide all the necessary support for the proper implementation of the guidelines at all levels of the national health laboratory systems and advancement of biosafety and biosecurity systems in Ethiopia.

Finally, I would also like to seize this opportunity to urge all stakeholders and valued partners to judiciously use the guidelines to promote the practical implementation of laboratory biosafety and biosecurity requirements towards ensuring the absolute protection of our health workers, community, and the environment from all potential risks of exposure and harm from biological agents, especially high-risk pathogens, at all times.

Mesay Hailu, PhD

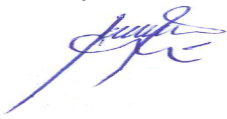

Director General, Ethiopian Public Health Institute

## II. Acknowledgement

The Ethiopian Public Health Institute and the Ministry of Health would like to acknowledge and thank the following institutions and individuals for their invaluable contributions to the successful development of this guidance document:

- CDC-Ethiopia for its financial support for the revision and printing of the guidelines.
- The World Bank for its financial support for the revision of the guidelines.
- Clinton Health Access Initiative for covering the costs related to conducting a number of workshops for reviewing the guidelines.
- Regional Public Health Institutes, Regional Reference Laboratories, Research institutes and Federal and Universities Hospitals for reviewing and providing feedback on these guidelines.
- Experts and professionals contributed to the preparation of this edition through participation in technical working groups, and subject matter experts.
- We also recognize the hard work and contributions made by all who participated in preparation of the previous edition of the guidelines; we have built on their solid work and commitment.

### III. List of Contributors

- Eyob Abera Mesfin (PhD, MPH, MSc) Biosafety and Biosecurity Advisor, Laboratory Quality System and Public Health expert, Ethiopian Public Health Institute, Addis Ababa, Ethiopia
- Tadesse Gerenfes (MSc), Biosafety and Biosecurity Expert, , Ethiopian Public Health Institute, Addis Ababa, Ethiopia
- Adinew Zewdu (MSc), Biosafety and Biosecurity Expert, , Ethiopian Public Health Institute, Addis Ababa, Ethiopia
- Yihalem Adamu (BSc), Occupational Health and Safety Expert, , Ethiopian Public Health Institute, Addis Ababa, Ethiopia
- Zelalem Messele (MPH, MBA), Senior Associate Scientist, CHAI, Addis Ababa, Ethiopia
- Adis Zewdie (MSc), Laboratory System Advisor, ,ICAP Ethiopian, Addis Ababa, Ethiopia
- Achamyeleh Mulugeta (MSc), Researcher, Ethiopian Public Health Institute, Addis Ababa, Ethiopia
- Habtamu Asrat (MSc), Laboratory Technical Advisor, ,APHL Addis Ababa, Ethiopia
- Wondwossen Kassa (MSc), Researcher, Ethiopian Public Health Institute, Addis Ababa, Ethiopia
- Tigist Getahun (MSc), Researcher, Ethiopian Public Health Institute, Addis Ababa, Ethiopia
- Bedasa Gidisa (MPH), Researcher, Ethiopian Public Health Institute, Addis Ababa, Ethiopia
- Megistu Tadesse (MSc), Laboratory advisor, Ethiopian Public Health Institute, Addis Ababa, Ethiopia
- Dawit Assefa Wendifraw (MSc), Diagnostic specialist USAID-IDDS ,Addis Ababa, Ethiopia
- Elias Seyoum (MSc), Researcher, Ethiopian Public Health Institute, Addis Ababa, Ethiopia
- Asdesach Tessema (MSc), Researcher, Ethiopian Public Health Institute, Addis Ababa, Ethiopia
- Feyissa Challa (MSc), Laboratory advisor, Ethiopian Public Health Institute, Addis Ababa, Ethiopia
- Gonfa Ayana (MSc), Laboratory Advisor, Ethiopian Public Health Institute, Addis Ababa, Ethiopia
- Yalew Gemechu(MSc), Researcher, Ethiopian Public Health Institute, Addis Ababa, Ethiopia
- Moa Abate (MSc), Researcher,Ethiopian Public Health Institute,Addis Ababa,Ethiopia
- Daniel Demissie,( MSc) Researcher, Ethiopian Public Health Institute, Addis Ababa, Ethiopia
- Kirubel Eshetu (MSc), Laboratory Advisor, MSH, Addis Ababa, Ethiopia
- Daniel Melese (MSc, MPH), Regional Laboratory Capacity Building Director , Ethiopian Public Health Institute, Addis Ababa, Ethiopia

<b>Table of Contents</b>	<b>Page</b>
I. Foreword .....	ii
II. Acknowledgement .....	v
III. List of Contributors.....	vi
IV. List of Table .....	xiii
V. List of Figures .....	xiv
VI. Acronyms and Abbreviations .....	xv
VII. Definition of Key Terms.....	xvi
<b>Chapter 1: Introduction and Scope of the Guidelines .....</b>	<b>1</b>
1.1 Introduction.....	1
1.2 Scope of the Guidelines.....	5
<b>Chapter 2: Management Roles and Responsibilities .....</b>	<b>6</b>
2.1. Management Roles.....	6
2.1.1. National Level.....	6
2.1.2. Regional Level.....	7
2.1.3. Health Facility Level.....	7
2.2. Responsibilities.....	7
2.2.1. Organization .....	7
2.2.2. Biosafety and Biosecurity Officer .....	8
2.2.3. The Laboratory Personnel .....	8
2.3. Training.....	9
2.4. Biosafety and Biosecurity Program Audit and Inspection .....	9
<b>Chapter 3: Risk Assessment .....</b>	<b>11</b>
3.1 Biorisk Assessment .....	12
3.1.1 Gather Information.....	14
3.1.2 Evaluate the Risks.....	16
3.1.3 Develop a Risk Control Strategy.....	20
3.1.4 Select and Implement Risk Mitigation Measures.....	21
3.2 Review Performance .....	22
<b>Chapter 4: Core Requirements.....</b>	<b>24</b>
4.1 Biosafety and Biosecurity Manual .....	24
4.2 Biohazards Control /Infection Control.....	25
4.3 Universal Precautions .....	25
4.4 Good Microbiological Practices and Procedures (GMPP).....	27
4.4.1 Best Practices .....	27
4.4.2 Hand Washing .....	28
4.4.3 Technical Procedures .....	28



4.4.4	Avoiding Inhalation of Biological Agents.....	28
4.4.5	Avoiding Ingestion of Biological Agents and Contact with Skin and Eyes .....	29
4.4.6	Avoiding Injection of Biological Agents .....	29
4.4.7	Biological Spill Response.....	30
4.5	Preventing Dispersal of Biological Agents .....	30
4.6	Personnel Competence and Training .....	31
4.7	Facility Design .....	31
4.8	Safe Handling Biological Hazardous Specimens.....	32
4.8.1	Collection of Clinical Specimen .....	33
4.8.2	Receiving Specimens.....	33
4.8.3	Specimens Processing .....	34
4.8.4	Specimen Storage .....	35
4.9	Disposal of Needles and Other Sharp Instruments.....	35
4.10	Aspiration from or Inoculation into Sterile Containers .....	36
4.11	Suction.....	36
4.12	Storage of Ampoules Containing Infectious Material .....	36
4.13	Opening of Ampoules Containing Lyophilized Infectious Material.....	37
4.14	Special Consideration for SARS-CoV-2 Virus Specimen Collection and Testing.....	37
4.14.1	Standard and Transmission-Based Precautions .....	37
4.14.2	Personal Protective Equipment .....	38
4.14.3	Safe Collection of Specimens for SAR-CoV2.....	38
4.14.4	Packaging and Shipping of Specimens .....	39
4.14.5	Storage of Specimens.....	39
4.14.6	Biosafety Practice at SARS-CoV-2 Virus Laboratory.....	39
4.14.7	Precautions When Performing Aerosol Generating Procedures .....	41
4.14.9	Decontamination and Cleaning Utilities and Surfaces Contaminated with COVID 19 Virus.....	42
4.14.10	Waste Management .....	42
<b>Chapter 5: Principles of Biosafety .....</b>		<b>43</b>
5.1	Containment.....	43
5.1.1	Safety Equipment (Primary Barriers) .....	43
5.1.2	Facility Design and Construction (Secondary Barriers) .....	44
5.1.3	Facility Practices and Procedures.....	44
5.2	Biosafety Levels .....	44
5.2.1	Biosafety Level 1.....	45
5.2.2	Biosafety Level 2 .....	46
5.2.3	Biosafety Level 3 .....	51
5.2.4	Biosafety Level 4 (Maximum containment) .....	55

5.2.5	Laboratory Animal Biosafety Levels.....	57
5.3	Classification of Microorganism Risk Groups .....	61
5.3.1	Risk Group 1 .....	62
5.3.2	Risk Group 2.....	62
5.3.3	Risk Group 3.....	62
5.3.4	Risk Group 4.....	62
<b>Chapter 6: Occupational Health and Safety .....</b>		<b>63</b>
6.1	Staff Induction .....	63
6.1.1	Staff Induction .....	63
6.2	Occupational Health and Safety Training.....	64
6.3	Pre-placement Medical Examination and Medical Surveillance program.....	64
6.3.1	Pre-Placement Medical Examination .....	64
6.3.2	Medical Surveillance Program .....	65
6.4	Exposure/Accident Management Plans.....	65
6.4.1	Occupational Exposure/Accident Management Plans .....	65
6.4.2	Incident Investigation, Mitigation and Reporting Plans .....	66
6.4.3	Incident/Accident Investigation .....	66
6.4.4	Incident/Accident Mitigation Plans .....	66
6.4.5	Incident/Accident Reporting.....	66
<b>Chapter 7: Laboratory Safety Equipment .....</b>		<b>67</b>
7.1	Personal Protective Equipment.....	67
7.1.1	Laboratory Coats, Gowns, and Aprons.....	67
7.1.2	Eye Protection.....	67
7.1.3	Gloves .....	68
7.1.4	Footwear.....	68
7.1.5	Respiratory Protection .....	68
7.2	Biosafety Cabinets (BSC) .....	70
7.3	Isolators.....	73
7.4	Local Exhaust Ventilation .....	74
7.5	Fume Hoods/ Cupboards.....	74
7.6	Laminar Flow Hood .....	74
7.7	Safety Considerations for Equipment Used for Laboratory Work .....	75
7.7.1	Biosafety Cabinets.....	75
7.7.2	Pipettes and Pipettors .....	76
7.7.3	Centrifuges .....	76
7.7.4	Homogenizers, Vortexes, Blenders and Sonicators .....	77
7.7.5	Autoclave .....	77

7.7.6	Water Baths .....	78
7.7.7	Microscopes .....	78
7.7.8	Laboratory Analyzers .....	78
7.7.9	Use of Refrigerators and Freezers .....	79
7.7.10	Equipment Decommissioning .....	79
<b>Chapter 8: Laboratory Biosecurity .....</b>		<b>81</b>
8.1	Biosecurity Risk Assessment .....	81
8.2	Inventory Control .....	83
8.3	Information Control.....	84
8.4	Personnel Control .....	84
8.5	Physical Security Control .....	85
8.6	Transport Control.....	85
8.7	Emergency/Incident Response Plan.....	85
8.8	Emerging Biotechnology Control .....	86
8.9	Dual Use Research of Concern .....	86
8.10	Select Hazardous Pathogens and Toxins .....	87
8.10.1	Criteria for Inclusion of Agents and Toxins into the Hazardous Pathogens and Toxins List .....	88
8.10.2	Requirements for Health Facilities Handling Select Hazardous Pathogens and Toxins..	88
<b>Chapter 9: Transportation of Biological Hazardous Substances.....</b>		<b>90</b>
9.1	Standard Techniques for Safe Management Of Biological Hazardous Substances.....	90
9.1.1	Handling of Biological Hazardous Substances.....	90
9.1.2	Transportation of Biological Hazardous Substances .....	91
9.1.3	Categories of Infectious Substance.....	91
9.1.4	Biological Hazardous Substance Transport Containment System .....	94
9.1.5	Packaging.....	95
9.2	Guidance for Spill Management during Sample Transportation.....	101
9.2.1	Handling of Specimen Spillage during Transport .....	102
9.2.2	List of Items in the Biological Spill Kit .....	103
<b>Chapter 10: Waste Management.....</b>		<b>104</b>
10.1	Types of Health-Care Waste.....	104
10.2	Risks Associated with Health-Care Waste Handling.....	105
10.3	Healthcare Waste Management .....	106
10.3.1	Waste Minimization .....	107
10.3.2	Healthcare Waste Collection and Segregation.....	107
10.3.3	Collection of Waste .....	108
10.3.4	Color-Coding System .....	109
10.3.5	Packaging.....	110

10.3.6	Waste Storage .....	110
10.3.7	Transportation of Waste .....	111
10.4	Treatment of Healthcare Waste .....	113
10.4.1	Infectious Waste Treatment.....	113
10.4.2	Mechanical Treatment .....	113
10.4.3	Chemical Disinfection .....	113
10.4.4	Heat Sterilization .....	114
10.4.5	Sterilization by Microwaves.....	114
10.4.6	Incineration .....	114
10.4.7	Treatment of Liquid Waste .....	114
10.5	Special Consideration for Waste Containing Guanidine Thiocyanate.....	115
10.6	Waste Disposal.....	116
10.6.1	Land Fill Disposal.....	116
10.6.2	Encapsulation and Inertization .....	116
<b>Chapter 11: Decontamination Methods.....</b>		<b>117</b>
11.1	Chemical Decontamination.....	117
11.1.1	Chemical Disinfectants and Germicides .....	117
11.1.2	Surface Decontamination.....	118
11.1.3	General Disinfection .....	118
11.1.4	Instrument Decontamination.....	119
11.1.5	Decontamination of Laboratory Instruments.....	119
11.1.6	Disinfectants against Spores and Mycobacteria .....	119
11.1.7	Disinfectants against Enveloped Viruses.....	119
11.1.8	Local Environmental Decontamination.....	119
11.1.9	Decontamination of Biological Safety Cabinets .....	120
11.2	Physical (Heat) Decontamination.....	120
11.2.1	Moist Heat Decontamination .....	121
11.2.2	Dry Heat Decontamination .....	123
11.3	Radiation .....	125
11.3.1	Ionizing Radiation.....	125
11.3.2	Non-Ionizing Radiation.....	125
11.4	High-Level Disinfection (HLD).....	125
11.4.1	High-level Disinfection Using Boiling in Water .....	126
11.4.2	High-Level Disinfection Using Steam.....	127
11.4.3	High-Level Disinfection Using Chemical Disinfectants.....	127
<b>Chapter 12: Other Laboratory Hazards.....</b>		<b>129</b>
12.1	Chemical Hazards .....	129
12.1.1	Classification of Chemicals.....	129

12.1.2	Storage of Chemicals .....	131
12.1.3	Handling of Chemicals .....	133
12.1.4	Hazardous Chemicals Categorization.....	134
12.1.5	Radiation Hazard .....	137
12.1.6	Material Safety Data Sheet (MSDS).....	138
12.1.7	Dealing with Chemical Spills.....	138
12.2	Fire Hazard .....	141
12.2.1	Fire Hazard Management .....	143
12.3	Electrical Hazards .....	143
12.4	Ergonomics.....	146
12.4.1	Responsibility .....	146
12.4.2	Maintaining Proper Posture in the Work Place .....	148
12.4.3	Poorly Design Work Station .....	148
12.4.4	Job Design.....	149
<b>Chapter 13: Emergency Preparedness and Response .....</b>		<b>151</b>
13.1	Emergency Preparedness.....	151
13.2	Emergency Equipment .....	152
13.2.1	Emergency Evacuations .....	153
13.2.2	Facility Utilities Information .....	153
13.3	Emergency Response .....	154
13.4	Emergency Preparedness and Response Training.....	154
<b>Reference.....</b>		<b>155</b>
<b>Annexes .....</b>		<b>157</b>
A.	Annex 1: Biosafety and Biosecurity Audit Checklist.....	157
B.	Annex 2: General Procedures for Spill Cleanup .....	163
C.	Annex 3: PPE Donning and Doffing Procedures.....	164
D.	Annex 4: HIV Exposure Reporting Form.....	166
E.	Annex 5: Incident Report Form.....	167
F.	Annex 5: General Description of Biological Agents/Materials .....	168
i.	Overview of Biological Agent/Material .....	168
ii.	Bacteria .....	168
iii.	Viruses.....	168
iv.	Fungi.....	169
v.	Parasites.....	169
vi.	Prions .....	170
vii.	Zoonotic Pathogens .....	171
viii.	Toxins .....	171
ix.	Genetically Modified Organisms .....	172

## IV. List of Tables

Table 1: Key considerations in the risk assessment framework.....	13
Table 2: Factors that affect the likelihood of an incident occurring.....	16
Table 3: Factors that affect the consequences of an incident if it would be occurred.....	17
Table 4: Risk assessment matrix.....	18
Table 5: Rating and classification of risk level and scoring including action to be taken.....	19
Table 6: Strategies for risk reduction.....	20
Table 7: Comparison of biosafety cabinet characteristics.....	72
Table 8: Summary of classification, categorization, identification and packaging of infectious substances and contaminated items with infectious substances. ....	93
Table 9 : Type of hazardous health-care waste .....	104
Table 10: Waste segregation, collection and color coding and type of waste containers recommendation .....	109
Table 11: Bleach preparation .....	118
Table 12: Temperatures and times recommended for autoclaving.....	124
Table 13: Hazard classification for chemicals.....	130
Table 14: List of some incompatible chemicals.....	132

## V. List of Figures

Figure 1: Risk assessment framework.....	12
Figure 2: Hierarchy of hazard controls .....	22
Figure 3: A typical design of biosafety level 2 laboratory (WHO 2004).....	48
Figure 4: A typical design of biosafety level 3 laboratory (WHO 2004).....	53
Figure 5: Type of class I BSC and its air flow direction .....	70
Figure 6: Type of class II BSC and its air flow direction.....	71
Figure 7: Type of class III BSC and its air flow direction.....	73
Figure 8: A description of the features of the UN specification mark for category A infectious substances packaging (for UN 2814 and UN 2900).....	96
Figure 9: Sign that labeled with packaging of category A.....	97
Figure 10: Orientation arrows with recommended colors.....	97
Figure 11: A triple package content for category A infectious substances (Adopted from WHO).....	98
Figure 12: A triple package content for category B infectious substances (Adopted from WHO).....	99
Figure 13: Hazard labels applicable to infectious substances shipments .....	101
Figure 14: Components of autoclave (WHO 2020).....	123
Figure 15: Label for corrosive chemicals or materials .....	135

## VI. Acronyms and Abbreviations

ABSL	Animal Facility Biosafety Level
AIDS	Acquired Immune-Deficiency Syndrome
BCG	Bacillus Calmette Guerin
BSC	Biological Safety Cabinets
BSL	Biosafety Level
CDC	Centers for Disease Control and Prevention
EPHI	Ethiopian Public Health Institute
ERPA	Ethiopian Radiation Protection Authority
HBV	Hepatitis B Virus
HCV	Hepatitis C Virus
HBIG	Hepatitis B Immunoglobulin
HEPA	High Efficiency Particulate Air
HIV	Human immunodeficiency Virus
VL	Viral Load
IATA	International Air Transport Association
EID	Early Infant Diagnosis
HCW	Healthcare Waste
GTC	Guanidinium thiocyanate
GMO	Genetically Modified Organism
HLD	High-level Disinfection
HSO	Health and Safety Officer
HSR	Health and Safety Representative
HVAC	Heating Ventilation and Air Conditioning
GMPP	Good Microbiological Practices and Procedures
ICAO	International Civil Aviation Organization
MSDS	Material Safety Data Sheet
PPE	Personal Protective Equipment
IPC	Infection Prevention and Control
PTFE	Poly Tetra Fluoro-Ethylene
RSO	Radiation Safety Officer
SOP	Standard Operating Procedure
TWG	Technical Working Group
UN	United Nations
OSH	Occupational Safety and Health
WHO	World Health Organization



## VII. Definition of Key Terms

**Accident:** An inadvertent occurrence that results in actual harm such as infection, illness, injury or contamination of the environment.

**Aerosol:** Liquid or solid particles suspended in air and of a size that may allow inhalation into the lower respiratory tract (usually less than 10 micrometers in diameter).

**Aerosol-generating procedure:** Any procedure that intentionally or inadvertently results in the creation of liquid or solid particles, which become suspended in the air (aerosols).

**Aerosol/airborne transmission:** The spread of infection caused by the inhalation of aerosols, or their deposition on mucosal surfaces of an exposed subject.

**Agent:** In a biological context, a microorganism, biological toxin, or human endoparasite, either naturally occurring or genetically modified, with the potential to cause infection, allergy, toxicity, or otherwise, create a hazard to human health.

**Antimicrobial:** An agent that kills microorganisms or suppresses their growth and multiplication.

**Antiseptic:** A substance that inhibits the growth and development of microorganisms without necessarily killing them. Antiseptics are usually applied to body surfaces.

**Aseptic techniques:** Conditions and procedural measures designed to effectively prevent contamination.

**Biological agent:** A microorganism, biological toxin, protein (prions) or human endoparasite, either naturally occurring or genetically modified, which may have the potential to cause infection, allergy, toxicity or otherwise create a hazard to human health, animals or plants.

**Biosafety officer:** An individual designated to oversee facility or organizational biosafety (and possibly biosecurity) programs. The person fulfilling this function may also be termed biosafety professional, biosafety advisor, biosafety manager, biosafety coordinator, or biosafety management advisor.

**Biological safety cabinet:** An enclosed, ventilated working space designed to provide protection to the operator, the laboratory environment and/or the work materials for activities where there is an aerosol hazard. Containment is achieved by segregation of the work from the main area of the laboratory and/or through the use of controlled, directional airflow mechanisms.

**Biological material:** refers to microorganisms, proteins, and nucleic acids, or anything that contains them (e.g., tissue) whether or not they are infectious or toxic. Pathogens are a subset of biological material that is capable of causing disease in humans or animals

**Biosafety:** Containment principles, technologies and practices that are implemented to prevent unintentional exposure to biological agents or their accidental release.

**Biosecurity:** Principles, technologies and practices that are implemented for the protection, control and accountability of biological materials and/or the equipment, skills and data related to their handling. Biosecurity aims to prevent their unauthorized access, loss, theft, misuse, diversion or release.

**Consequence:** The outcome of an incident (exposure to and/ or release of a biological agent) of varying severity of harm, occurring in the course of laboratory operations. Consequences may include a laboratory-associated infection, other illness or physical injury, environmental contamination, or asymptomatic carriage of a biological agent.

**Contact time:** The time required for a process or chemical treatment to inactivate a microorganism on the surface or item, which may depend on the number of organisms present and other variables (e.g., temperature, organic load, water hardness).

**Containment:** The combination of physical design parameters and operational practices that protect personnel, the immediate work environment and the community from exposure to biological agents. It is of note, however, that the levels of containment, such as primary and secondary containment, are relative, subject to the actual usage, and combination of devices and apparatuses. The term "biocontainment" is also used in this context.

**Core requirements:** A set of minimum requirements defined in the fourth edition of the World Health Organization (WHO) *Laboratory biosafety manual* to describe a combination of risk control measures that are both the foundation for, and an integral part of, laboratory biosafety. These measures reflect international standards and best practice in biosafety that are necessary to work safely with biological agents, even where the associated risks are minimal.

**Decontamination:** Reduction of viable biological agents or other hazardous materials on a surface or object(s) to a pre-defined level by chemical and/or physical means.

**Disinfectants:** Agents capable of eliminating viable biological agents on surfaces or in liquid waste. These will have varying effectiveness depending on the properties of the chemical, its concentration, shelf life and contact time with the agent.

**Disinfection:** A process to eliminate viable biological agents from items or surfaces for further safe handling or use.

**Emergency/incidence response plan:** An outline of the behaviors, processes and procedures to be followed when handling sudden or unexpected situations, including exposure to or release of biological agents. The goal of an emergency/incidence response plan is to prevent injuries or infections, reduce damage to equipment or the environment, and accelerate resumption of normal operations.

**Encapsulation:** involves filling containers with waste, adding an immobilizing material, and sealing the containers

**Engineering controls:** Risk mitigation measures that are built into the design of a laboratory or pre-installed in laboratory equipment in order to minimize the risk of exposure to and/or unintended release of biological agents.

**Exposure:** An event during which an individual comes in contact with, or is in close proximity to, biological agents with the potential for infection or harm to occur. Routes of exposure can include

inhalation, ingestion, intravenous injection and absorption and are usually dependent upon the characteristics of the biological agent. However, some infection routes are specific to the laboratory environment and are not commonly seen in the general community.

**Exotic disease:** A disease not normally occurring in a particular region or area, often imported from another area. It can also be referred to as non-indigenous disease.

**Good microbiological practices and procedures (GMPP):** A basic laboratory code of practice applicable to all types of activities with biological agents, including general behaviors and aseptic techniques that should always be observed in the laboratory. These practices and procedures serve to protect laboratory personnel and the community from infection, prevent contamination of the environment, and provide protection for the work materials in use.

**Hazard:** An object or situation that has the potential to cause adverse effects when an organism, system or (sub) population is exposed to it. In the case of laboratory biosafety, the hazard is defined as biological agents which have the potential to cause adverse effects to personnel and/or humans, animals, and the wider community and environment. A hazard does not become a “risk” until the likelihood and consequences of that hazard causing harm are taken into account.

**Inactivation:** A process to reduce the ability of biological agents to grow and/or multiply and/or have pathogenic functions.

**Incident:** An occurrence that has the potential to, or results in, the exposure of laboratory personnel to biological agents and/or their release into the environment that may or may not lead to actual infection.

**Infectious dose:** The amount of biological agent required to cause an infection in the host, measured in number of organisms. Often defined as the ID<sub>50</sub>, the dose that will cause infection in 50% of those exposed.

**Infectious substances:** The term applied for the purposes of transport to any material, solid or liquid, which contains biological agents capable of causing infection in either humans, animals or both. Infectious substances can include patient specimens, biological cultures, medical or clinical wastes and/or biological products such as vaccines.

**Health laboratory:** It is a laboratory where tests are carried out on human, animal, and or environmental specimens to obtain information about the health of individuals, animals, or the environment to aid in diagnosis, treatment, prevention of disease, and research.

**Inherent risk:** Risk associated with laboratory activities or procedures that are conducted in the absence of mitigation measures or controls.

**Laboratory-associated infection:** Any infection acquired as a result of exposure to a biological agent in the course of laboratory-related activities, including secondary or tertiary infections. They are also known as laboratory-acquired infections.

**Likelihood:** The probability of an incident (i.e. exposure to and/or a release of a biological agent) occurring in the course of laboratory work.

**Maximum containment measures:** A set of highly detailed and stringent risk control measures that are considered necessary for laboratory work where a risk assessment indicates that the activities to be performed pose very high risks to laboratory personnel, the wider community and/or the environment and therefore an extremely high level of protection must be provided. These are especially needed in the case of work with biological agents that may have catastrophic consequences if an exposure or release were to occur.

**Pathogen:** A biological agent capable of causing disease or infection in humans, animals or plants.

**Personal protective equipment:** Equipment and/or clothing worn or held e.g. a monitor by personnel to provide a barrier against biological agents, thereby minimizing the likelihood of exposure. PPE includes, but is not limited to, laboratory coats, gowns, full-body suits, gloves, protective footwear, safety glasses, safety goggles, masks and respirators.

**Primary containment device (equipment):** A contained workspace designed to provide protection to its operator, the laboratory environment and/or the work materials for activities where there is an aerosol hazard. Protection is achieved by segregation of the work from the main area of the laboratory and/or through the use of controlled, directional airflow mechanisms. Primary containment devices include biological safety cabinets (BSCs), isolators, local exhaust ventilators and ventilated working spaces.

**Prophylaxis:** Treatment given to prevent infection or to mitigate the severity of the disease if infection were to occur. It can be delivered before possible exposure or after exposure before the onset of infection.

**Risk:** A combination of the likelihood of an incident and the severity of the harm (consequences) if that incident were to occur.

**Residual risk:** Risk that remains after carefully selected risk control measures have been applied. If residual risk is not acceptable, it may be necessary to apply additional risk control measures or to stop the laboratory activity.

**Risk assessment:** A systematic process of gathering and evaluating information to support a risk-management process.

**Risk evaluation:** Part of risk assessment where the likelihood of exposure to a hazard is weighed against the potential severity of harm under a set of predefined circumstances, such as a specific laboratory procedure. The goal of a risk evaluation is to determine whether the assessed risk is acceptable, or whether further targeted control measures should be implemented to prevent or reduce the risks to within a tolerance level.

**Risk control measures:** Use of a combination of tools, which include communication, assessment, training, and physical and operational controls, to reduce the risk of an incident/event to an acceptable level. The risk assessment framework will determine the strategy that should be taken to control the risks and the specific types of control measures required to achieve this.

**Risk tolerance:** The level of risk that is considered acceptable and allows work to proceed bearing in mind the expected benefit of the planned activities.

**Sterile:** The state of having a complete absence of viable biological agents and spores.

**Sterilization:** Process used to render a product free of viable biological agents, including bacterial spores.

**Transmission:** The transfer of biological agent(s) from objects to living things, or between living things, either directly or indirectly via aerosols, droplets, body fluids, vectors, food/water or other contaminated objects.

**Verification:** Confirmation that a given item (product, process or system) satisfies the specified requirements. For example, verification that the performance of an autoclave meets the standards specified by the manufacturer should be performed periodically.

# Chapter 1: Introduction and Scope of the Guidelines

## 1.1 Introduction

Implementation of laboratory biosafety and biosecurity activities is fundamental to protecting the laboratory workforce and the wider community against unintentional exposures or releases of pathogenic biological agents. These activities are implemented through the development of a safety culture, which is needed to ensure a safe workplace where adequate measures are applied to minimize the likelihood and severity of any potential exposure to biological agents. The level of implementation and adherence to biosafety and biosecurity principles and practices in biomedical laboratories underpin the establishment of an effective biorisk management system, the achievement of which primarily depends on the knowledge, skills, and overall competency of personnel working in these settings. It is required that laboratory personnel meticulously follow safe working guidelines and procedures for handling, manipulating, and containing pathogenic microorganisms (biosafety) while strictly adhering to preset organizational policies and arrangements made to keep their work and materials safe and secure from potential risks of misuse or abuse (biosecurity). Although laboratory biosafety and biosecurity activities aim at managing different risks, they complement and reinforce each other in building the foundation of a comprehensive biorisk management system that seeks to promote and ensure the health and well-being of laboratory personnel and the public at large through protecting them from exposure to infectious pathogens and hazardous toxins.

Over the past years, awareness and expertise in biosafety and biosecurity principles and practices have greatly improved; new methods and technologies, such as the use of molecular methods, have advanced considerably and reduced the number of diagnostic activities that require propagation of high-titer biological agents. Similarly, rapid developments in the field of engineering sciences and safety standards for the designing, construction, and finishing of biological laboratory facilities have resulted in improved physical infrastructure featuring advanced engineering controls that enable the employment of high-efficiency biocontainment equipment systems and the effective implementation of administrative controls. Despite these encouraging advances in risk awareness and expertise, including rapid improvements in analytical methods and technologies, biosafety and biosecurity remains one of many developing countries' weakest core capacities, as identified by various IHR monitoring and evaluation activities. This has been largely attributed to the low level of organizational and financial resources available for the implementation of biological risk management programs and the lack of national regulatory frameworks to guide the roles, responsibilities, and accountabilities of all concerned for risk identification and mitigation efforts both at laboratory and

higher management levels, including structured systems for compliance monitoring and evaluation. Mainly as the logical consequences of these limitations, inadequate or very little progress could be made in engraining the concepts and importance of biosafety and biosecurity in the minds of laboratory personnel, which would have helped facilitate the establishment and maintenance of a comprehensive biosafety culture in the laboratory environment. A robust and responsible safety culture would translate into a deeper understanding and routine application of safe practices, procedures, actions, and appropriate patterns of behavior while working with biological agents or their products. Clearly substantiating this fact, a review of recent laboratory-associated infections showed that most were caused by human factors rather than malfunctions of engineering controls. Factors that have led to potential and confirmed exposures to biological agents include the absence or improper use of personal protective equipment (PPE), inadequate or inattention to risk assessments, a lack of standard operating procedures (SOPs), needle stick injuries, and/or insufficiently trained personnel. As a result, it can be argued that the safety of even the best designed and engineered laboratory is only as good as its least competent employee.

This very important observation unequivocally underscores the critical importance of building the capacity of laboratory personnel on how to systematically and effectively confine infectious organisms or toxins in order to reduce the potential exposure of laboratory workers or persons outside the laboratory, as well as minimize the likelihood of accidental release to the environment. It is thus of paramount importance that a country's laboratory leadership develops strategies and detailed guidelines for the systematic practical implementation of the basic concepts and principles of laboratory biosafety and biosecurity, based on which essential tools for comprehensive capacity building, biorisk assessment, and management could be developed and made accessible to all public and private health laboratories, including those of biomedical research institutions dealing with biological agents or their products. The need to develop strategies and implementation guidelines for biosafety and biosecurity is part of a broader national initiative towards complying with WHO's International Health Regulations of 2005, which require member countries to be well prepared for a rapid and effective response to potential disease outbreaks through early diagnosis, confirmation, and communication by laboratories. Accordingly, reliable national capacity for laboratory biosafety and biosecurity is one of the technical areas assessed as part of the monitoring and evaluation framework of the International Health Regulations, underlining the importance of safe and secure laboratory operations and practices as one of the essential components of compliance with the Regulations and informed prevention of serious public health threats.

The first edition of Health and Safety Guidelines for Public Health Laboratories in Ethiopia was published in 2010. Since then, the document has particularly served as an important resource and guiding tool for the practical implementation of the fundamental principles of biosafety across the Ethiopian health laboratory system. Despite its valuable contribution to the systematic introduction and improved implementation of basic health laboratory biosafety principles and standards in this country, the guidance document had significant limitations in its overall scope, with an exclusive focus on biosafety while totally lacking a biosecurity component, and negligibly little or no details on a framework or structure for systematic and effective risk management based on evidence from regular risk assessments, identification, analysis, and evaluations as per the current international standards, recommendations, and practices. Although the document adequately addresses the conceptual framework for the implementation of biosecurity principles and requirements in a health laboratory setting, it provides insufficient details on prioritized approaches and organized schemes for seamless programmatic implementations with clearly defined specific roles and responsibilities for all concerned stakeholders and partners.

Furthermore, over the years since the publication of this first guidance document, a lot of technological developments have taken place in the field of diagnostic laboratories, particularly in the areas of molecular diagnostics, which in many instances have circumvented activities involving the propagation of high-titer biological agents, thus reducing potential biorisks, while some have led to the excessive generation of new hazardous wastes such as guanidinium thiocyanate, exacerbating the existing challenges of protecting the environment from the soaring burden of chemical wastes. The ever increasing recognition of the key role of laboratories in the prevention, detection, and response to public health emergency situations due to emerging and re-emerging infectious agents has been putting high demand on the laboratory system for the introduction and expansion of novel tests and innovative technologies to several clinical diagnostic, public health, and research laboratories, including those in animal care facilities. In the face of such rapid global developments and heightened needs for strong biorisk management systems, it is crucial that resource-constrained countries make their utmost efforts to implement economically feasible and sustainable laboratory biosafety and biosecurity policies and practices that are relevant to their specific individual circumstances and priorities. The first and most important activity should be to review and update national implementation tools, such as guidelines, risk assessment protocols and procedures, and so on, in light of new knowledge on the pathogenic characteristics of the biological agents under consideration, methods and techniques involved, equipment used, and international guidance and recommendations provided for optimum containment through the implementation of the best possible biosafety and containment protocols.



The second is building the capacity and capability of laboratory facilities for self-risk assessment, as particularly related to personnel awareness and competence in biosafety and biosecurity principles and practices, the adequacy of basic infrastructure, including all necessary equipment with sufficient engineering controls that can be readily supported and enhanced by appropriate administrative controls, etc. Thirdly, prioritization of gaps and development of a biosafety and biosecurity action plan for implementation at national, regional, and facility biorisk management levels commensurate with available resources. At the fourth and most critical stage of implementation, the primary focus and goal should be building the necessary core capacity of each level for sustainable promotion of an evidence-based biorisk management system, as supported by risk identification and prioritization, awareness creation, and clear communications among all stakeholders and partners for well-coordinated and productive collaborative mitigation efforts. It is especially important to strive for a large population base of laboratory personnel at all times by cultivating and nurturing a thorough understanding of biosafety and biosecurity requirements to the point of instilling a safety culture consistent with Good Microbiological Practice and Procedure (GMPP) and a standard code of conduct for the responsible laboratory use of biological agents and materials. As the world continues to face ever increasing challenges in safeguarding the public health from potential bioterrorism, it is imperative that stringent and foolproof biosecurity arrangements are instituted and conscientiously heeded at all times in order to protect high-risk biological pathogens and toxins from theft, loss, or misuse.

The necessity for establishing and maintaining a functional biosafety and biosecurity system is a matter of national public health security and a fundamental requirement for compliance with International Health Regulations, so much so that a country should have clear national strategies, implementation guidelines, the necessary regulatory frameworks, organizational preparedness, and an unwavering commitment to the allocation of adequate financial resources for the effective management of public health risks posed by biological agents and toxins at all levels of the laboratory system and beyond. Reliable financial resources and action-oriented leadership at all levels of the national health laboratory system are crucial for the development of sustainable capacities to identify, store, and securely handle dangerous biological agents and toxins according to international standards and best practices. Undertaking biorisk assessment and evaluation, risk prioritization, and the development of mitigation action plans; developing appropriate platforms for sensitization and advocacy; training personnel and providing mentoring and coaching support; improving facility infrastructure; and monitoring and evaluating implementation for continuous performance enhancement are all resource-intensive activities that necessitate careful planning by a committed leadership with the participation of stakeholders. The publication of this guidance document is

believed to facilitate the seamless and coordinated execution of these activities toward establishing and strengthening a functional biorisk management system across all health laboratories in Ethiopia.

## **1.2 Scope of the Guidelines**

This guidance document adopts a risk- and evidence based approach to biosafety and biosecurity in order to ensure that laboratory facilities, safety equipment, and work practices are relevant, appropriate, and sustainable. It also emphasizes the importance of safety practices that incorporate risk assessment, good microbiological practices and procedures, incident management, and safe waste disposal.

The document is intended to provide guidance specifically for those who work with biological agents or in facilities where personnel may be exposed to potentially infectious substances that present a hazard to human health. It is also believed to be of value to those who develop and implement biosafety and biosecurity programs at facilities or regional levels. Unlike the previous edition, this document provides detailed guidance on how to manage the security of biological agents and toxins and the threats posed to human and animal health, the environment, and the economy by deliberate release, misuse, or abuse.

All in all, this document is believed to guide the sustainable development of laboratory biosafety and biosecurity capacity in Ethiopia, facilitate a comprehensive and integrated approach to implementing laboratory biosafety and biosecurity systems, and promote responsible laboratory use of biological agents and materials. Furthermore, utmost efforts have been made to enrich the documents with current scientific knowledge and best practices, international guidance, and recommendations as related to building a national core capacity in biosafety and biosecurity so as to capably comply with International Health Regulations.

## Chapter 2: Management Roles and Responsibilities

Effective implementation of this guideline will require proper coordination from the national level all the way to the lowest health facilities. A biosafety and biosecurity committee should be formed at each level to strengthen coordination in the implementation of the guideline. Health facility management should be in charge of leading and allocating resources for the implementation of biosafety and biosecurity guideline. As indicated below, there are various levels of responsibility and authority for biosafety and biosecurity lead persons.

### 2.1. Management Roles

#### 2.1.1. National Level

At the national level, the Ethiopian Public Health Institute (EPHI) has the ultimate responsibility and authority for ensuring the availability, implementation and monitoring of use of the biosafety and biosecurity guideline. EPHI management is responsible for coordination of the biosafety and biosecurity programs. The management is also responsible for ensuring funding to support the program and for providing oversight of the implementation and ongoing review of the program. The EPHI's biosafety and biosecurity team is responsible for the development and implementation of the biosafety and biosecurity guidelines as well as the preparation of a standardized biosafety and biosecurity training package.

Furthermore, a biosafety and biosecurity technical working group (TWG) should be established to monitor the effective implementation of biosafety and biosecurity programs, with TWG members representing various institutions of health, agriculture, environmental protection agencies, biotechnology institutes, legal enforcement organizations, veterinary institutes, information technology institutions, and professional societies. The TWG will have the following roles and responsibility but not limited to these:

- Advise the implementation of appropriate biosafety and biosecurity measures and mitigation strategies.
- Review and provide recommendation on biosafety and biosecurity regulatory framework.
- Review the national, regional, and institutional biosafety and biosecurity implementation activity.
- Oversee and evaluate biosafety and biosecurity guidelines, procedures and activities are aligned with national and international regulations.
- Strengthen coordination and implementation of the guidelines.

- Participate in strategic planning, advocacy, and resource mobilization.

### **2.1.2. Regional Level**

Each region should establish a regional biosafety and biosecurity committee, mobilize resources, build capacity, and monitor and evaluate implementation of biosafety and biosecurity. The committee should comprise of different professionals from each sector (public health, health institutions, university agriculture, research institutes, animal health, environmental health, regulatory body etc.) and the committee should be chaired by a regional health bureau, public health institute, or regional reference laboratories. The committee will be responsible for monitoring the implementation of the biosafety and biosecurity guidelines at public health institutes/Regional Reference Laboratories, hospitals, and health center laboratories in their respective region.

### **2.1.3. Health Facility Level**

The management of the health facility should incorporate a biosafety and biosecurity committee into the existing IPC team. If possible, establish a separate Biosafety and Biosecurity committee comprised of different disciplines and work in close collaboration with the infection prevention and control (IPC) committee. The Biosafety and Biosecurity committee should serve as an independent review group for biosafety problems, reporting to the facility management.

## **2.2. Responsibilities**

### **2.2.1. Organization**

Each organization at the national and regional level should establish biosafety and biosecurity committees and assign a biosafety and biosecurity officer. The implementation of biosafety and biosecurity systems should be integrated with quality improvement initiatives. The organization is responsible for ensuring that the health of personnel is adequately monitored. The organization will have the following roles and responsibilities, but not be limited to these:

- Provide a safe and healthy work environment, ensure required safety equipment are available at the point of use, facilitate provision of active or passive immunization where applicable, provide occupational safety and Health (OSH) training for all healthcare workers, ensure all work hazards are identified with adequate mitigation measures and healthcare workers made aware of hazards and mitigation measures.

- Provide effective protection of the worker to hazard exposure including: Engineering control, personal protective equipment (PPE) and train all workers on the use of protection equipment provided.
- Put a system in place for accident and incident reporting that should include management and post exposure monitoring of occupational-acquired infections and accidents.
- Train staff on all aspects of biosafety and biosecurity to keep up-to-date with the current practices.

### **2.2.2. Biosafety and Biosecurity Officer**

Each healthcare facility in the country should have a biosafety and biosecurity officer. The officer shall be appointed by (identified and recommended by the committee according to set criteria) the head of the laboratory. The officer must have the appropriate technical background and be well experienced in biosafety and biosecurity issues. The officer will be appointed to ensure that safety policies and programs are followed consistently.

The activities of the officer include but not limited to the following

- Perform safety audit.
- Coordinate risk assessment activities.
- Ensure documentation of all biosafety and biosecurity procedures and activities.
- Provision of up-to-date biosafety and biosecurity information.
- Investigation of accidents and incidents.
- Prepare and share report of biosafety and biosecurity regularly.
- Establishment of procedures for recording the receipt, movements, and disposal of pathogenic material.
- Review the safety aspects of all plans, protocols, and operating procedures.
- Develop a system (plan) to deal with any emergencies (as per the risk assessment) that arise in the laboratory.
- Coordinate orientation to new staff, visitors, researchers, and students to ensure compliance.

### **2.2.3. The Laboratory Personnel**

Each laboratory worker shares the responsibility for safety in the laboratory with the following elements, but not limited to these:

- Adhere to Good Laboratory Practice (GLP).

- Report and record all accidents and biohazardous exposures, work related illnesses to the appointed biosafety and biosecurity officer and/or the supervisor.
- Follow all work protocols and operating procedures applicable to their activities.
- Understand the risks of the project, procedures, and activities he or she is undertaking.
- Take appropriate safety measures to protect themselves, co-workers, and the environment.
- Use personal protective equipment as prescribed at all time when on duty.
- Complete all necessary training for the assigned tasks and responsibilities.

### **2.3. Training**

A safety-conscious staff, well informed about the recognition and control of laboratory hazards, is key to the prevention of acquired infections, incidents, and accidents in the facility. So that the facility should provide biosafety and biosecurity training for all laboratory personnel and researchers, including specimen collectors, couriers, drivers, cleaners, animal attendants, and supportive staff. The training program should include an introduction for new employees and periodic retraining for experienced employees, and it should be conducted regularly.

At a minimum, a safety training program should address biological hazards and infection prevention, chemical and radiation safety, fire prevention and preparedness, first aid, and other related safety training. There shall be a system for evaluating each employee's understanding of the information given to them. For an effective safety program, laboratory managers should ensure that safe laboratory practices and procedures are integrated into the basic training of employees.

### **2.4. Biosafety and Biosecurity Program Audit and Inspection**

The purpose of the audit and inspection is to assess the facility's health and safety management system and the effectiveness of control measures. The facility ensures that the biosafety and biosecurity programs should be audited at least annually and the audit should be conducted by competent personnel. The program should focus on the following elements but not limited to these (the facility can use or customize the Biosafety and Biosecurity Audit Checklist annexed as Annex 1):

- safety and health policy
- written work procedures that include safe work practices
- education and training of laboratory-associated staff
- supervision of workers

- regular inspections
- hazardous materials and substances
- biosecurity practice
- health surveillance
- first aid services and equipment
- investigation of accidents and illnesses
- health and safety committee review
- records and statistics.
- Review of safety program with requirement for follow-up to ensure that all required actions arising from the audit are completed.

Facility management is responsible for ensuring that safety inspections are undertaken. Work sites shall be surveyed/inspected at bi-annually. This is to ensure:

- the proper state of readiness and function of fire emergency apparatus, alarms and evacuation procedures,
- the status of procedures and materials for hazardous spillage containment, including emergency showers,
- the proper containment and control for the storage of flammable and combustible, infective, radioactive and toxic materials
- the status of decontamination and disposal procedures.
- the hazardous pathogen and toxins use and storage.

## Chapter 3: Risk Assessment

The term risk assessment refers to the step-by-step process of evaluating the risk(s) associated with working with a hazard(s) and using the resulting information to determine whether risk control measures can be used to reduce those risks to acceptable levels. Risk is the combination of the probability that a hazard will cause harm and the severity of harm that may arise from contact with that hazard.

Risk assessments must always be conducted in a standardized and systematic way. For this reason, many organizations offer risk assessment templates, checklists, or questionnaires that provide stepwise approaches to identify, evaluate, and determine risks associated with the hazards present, before using this information to identify appropriate risk control measures. Risk assessment process can be divided into three primary components: assessment, mitigation, and performance review. A risk assessment should be performed by the laboratory before beginning any laboratory activities or when any of the following conditions occur:

- changes to personnel,
- changes to procedures and practices,
- changes to laboratory equipment,
- introduction of new technology,
- changes in regulations or guidelines,
- laboratory relocation or renovation,
- changes to biological agents or new information available on current biological agents,
- an incident, accident, laboratory-associated infection, or any event where a potential for harm is identified,
- identification and/or implementation of corrective and/or preventive action,
- user feedback, and
- a periodic review.

Although there are several types of hazards in health laboratories, this chapter focuses on biorisk assessment and management and also describes a step-approach risk assessment method that gives structure to the biorisk assessment and management process..



### 3.1 Biorisk Assessment

A biorisk assessment is a process used to identify the hazardous characteristics of a known infectious or potentially infectious agent or material, the activities that can result in a person’s exposure to an agent, the likelihood that such exposure will cause laboratory-acquired infections (LAIs), and laboratory biosecurity risks (risks of unauthorized access, loss, theft, misuse, diversion, or intentional release) and their potential consequences. Risk can be described as the combination of the likelihood (or probability) and the consequences of an undesirable event. A risk can be based on either a hazard or a threat. A risk assessment is the fundamental process to help determine, mitigate, and manage laboratory risks. A good risk assessment system informs decisions intended to reduce the risks present in a laboratory.

Any facility that handles biological agents has an obligation to their personnel and the community to perform a biorisk assessment on the work they will conduct and to select and apply appropriate control measures to reduce those risks to an acceptable level. The purpose of the risk assessment is to gather information, evaluate and use to inform and justify the implementation of processes, procedures, and technologies to control the risks present. Analysis of this information empowers laboratory personnel as it gives them a deeper understanding of the biological risks and how they can affect them. It helps create shared values, patterns of behavior and perceptions of the importance of safety and makes laboratory personnel more likely to conduct their work safely and maintain a safety culture in the laboratory figure 1.

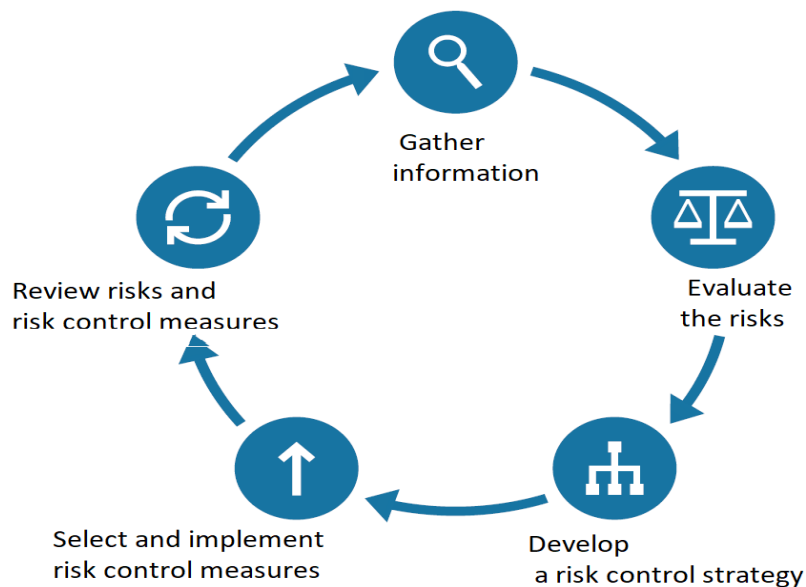

Figure 1: Risk assessment framework

Biorisk assessments should be conducted in a standardized and systematic way to ensure they are repeatable and comparable in the same context. The various steps of the risk assessment process collectively form a risk assessment framework. The steps in the risk assessment framework are depicted in figure 1.

Where Figure 1 illustrates the steps in the risk assessment framework, Table .1 provides an overview of the key considerations that apply during each step of the cycle, it is important to note that not all factors will affect risk in the same way, but each should be carefully considered. When conducting a risk assessment, it must be remembered that the level of risk is not based on the pathogenicity of the biological agent alone, but on the likelihood and consequence of an incident occurring—in other words, the risk of exposure to and/or release of the biological agent during laboratory operations. An approach to assess risks consists of the following steps:

Table 1: Key considerations in the risk assessment framework

Step	Key considerations
1. Gather information (hazard identification)	<ul style="list-style-type: none"> <li>▪ What biological agents will be handled and what are their pathogenic characteristics?</li> <li>▪ What type of laboratory work and/or procedures will be conducted?</li> <li>▪ What volume test a laboratory does perform at work hours?</li> <li>▪ What type(s) of equipment will be used?</li> <li>▪ What type of laboratory facility is available?</li> <li>▪ What human factors exist (e.g. what is the level of competency of personnel)?</li> <li>▪ What other factors exist that might affect laboratory operations (e.g. legal, cultural, socioeconomic, public perception)?</li> </ul>
2. Evaluate the risks	<ul style="list-style-type: none"> <li>▪ How could an exposure and/or release occur?</li> <li>▪ What is the likelihood of an exposure and/or release?</li> <li>▪ What information gathered influences the likelihood the most?</li> <li>▪ What are the consequences of an exposure and/or release?</li> <li>▪ Which information gathered influences the consequences the most?</li> <li>▪ What is the overall inherent risk of the activities?</li> <li>▪ What is the risk tolerance level?</li> <li>▪ Which risks are above the risk tolerance level?</li> <li>▪ Can the unacceptable risks be controlled, or should the work not proceed at all?</li> </ul>
3. Develop a risk control strategy	<ul style="list-style-type: none"> <li>▪ What resources are available for risk control?</li> </ul>

	<ul style="list-style-type: none"> <li>▪ What risk control strategies are most applicable for the resources available?</li> <li>▪ Are resources sufficient to obtain and maintain those control measures?</li> <li>▪ Are proposed control strategies effective, sustainable, and achievable in the local context?</li> </ul>
4. Select and implement control measures	<ul style="list-style-type: none"> <li>▪ Are there any national/international regulations requiring prescribed control measures?</li> <li>▪ What control measures are locally available and sustainable?</li> <li>▪ Are available controls adequately efficient, or should multiple controls be used in combination to enhance efficacy?</li> <li>▪ Do selected control measures align with the risk control strategy?</li> <li>▪ What is the level of residual risk after control measures have been applied and is it now acceptable/within the tolerance level?</li> <li>▪ Are additional resources required and available for the implementation of control measures?</li> <li>▪ Are the selected control measures compliant with national/ international regulations?</li> <li>▪ Has approval to conduct the work been granted?</li> <li>▪ Have the risk control strategies been communicated to relevant personnel?</li> <li>▪ Have necessary items been included in the budget and purchased?</li> <li>▪ Are operational and maintenance procedures in place?</li> <li>▪ Have personnel been appropriately trained?</li> </ul>
5. Review risks and control measures	<ul style="list-style-type: none"> <li>▪ Have there been any changes in activities, biological agents, personnel, equipment, or facilities?</li> <li>▪ Is there any new knowledge available of biological agents and/or the processes being used?</li> <li>▪ Are there any lessons learned from incident reports and investigations that may indicate improvements to be made?</li> <li>▪ Has a periodic review cycle been established?</li> </ul>

### 3.1.1 Gather Information

Those conducting a risk assessment must collect and consider a wide range of information in order to accurately evaluate the risks and appropriately select the control measures needed to reduce risks to acceptable levels in the laboratory. This information goes beyond identifying the hazards (–the biological agents being used )and considers the procedural and contextual situations that contribute to the overall risk. Key information to be gathered should include for example:

- Laboratory activities planned (e.g. procedures, equipment, animal work, sonication, aerosolization and centrifugation),

- Competency of the personnel carrying out the work,
- Concentration and volume of the biological agent and potentially infectious material to be manipulated,
- Potential routes of transmission,
- The Infectious dose of the biological agent,
- Communicability of the biological agent,
- The Severity of infection with the biological agent,
- Local availability of effective prophylaxis or therapeutic interventions,
- Stability of the biological agent in the laboratory and external environment,
- Susceptibility of laboratory personnel (e.g. at-risk individuals),
- Range of hosts of the biological agent (i.e. zoonotic potential),
- Endemicity of the biological agent in the local population,
- Frequency of equipment and building failures (e.g. power, building infrastructure and systems).

All the above-mentioned information collectively informs a much broader, multifactorial evaluation of the level of risk that may exist in the laboratory. Information on all these factors is essential as various combinations of biological agents and activities may pose greater risks in some situations than in others. Performing research on a biological agent that is not prevalent in the local community will pose a greater risk than performing the work in a region where it is endemic. It is important to remember that gathering information should also include defining the attributes of the laboratory environment, such as the condition of the building and laboratory areas where the work will be conducted.

#### **3.1.1.1 Information on New or Unknown Biological Agents**

Where new agents are being used, or there are specimens for which detailed data are unknown, the information available may be insufficient to be able to carry out a comprehensive risk assessment. This applies to clinical samples collected in the field during potential outbreak investigations. In such cases, it is sensible to take a cautious approach to specimen manipulation and handle all materials as potentially infectious. Certain information should be requested, where possible, to assist in determining the risks associated with handling such specimens including:

- Medical data on the patient from whom the specimen was taken,
- Epidemiological data (severity and mortality data, suspected route of transmission, other outbreak investigation data), and
- Information on the geographical origin of the specimen.

In the case of an outbreak of a disease of unknown etiology, appropriate guidelines can be produced by competent national or international authorities to indicate how specimens are to be handled safely. This may include how specimens should be prepared for shipment as well as specific control measures that should be implemented.

### 3.1.2 Evaluate the Risks

After gathering all available information on the circumstances of the work to be performed, it is necessary to use that information to identify and evaluate any risks that exist. The goal of the risk evaluation step is to:

- Determine the likelihood of an exposure and/or release of a biological agent occurring and the severity of the consequences of such an event,
- Establish how the likelihood and consequence contribute to the inherent risk of the work to be performed,
- Decide, based on the gathered information of the risk assessment, whether these risks are acceptable or not, this decision must be justified and documented comprehensively.

If the evaluated risks are not acceptable, proceed to the next step of the risk assessment framework and develop an appropriate risk control strategy, unless the work is not undertaken at all.

#### 3.1.2.1 Determine the Likelihood and Consequence

Evaluation of the information gathered should first include the determination of the likelihood of an exposure and/or release of a biological agent occurring, and of the severity of the associated consequences. It is these factors, when considered together, that will ultimately determine the overall, or inherent risk, of the situation for which the information has been gathered (Table 2).

Table 2: Factors that affect the likelihood of an incident occurring

Factors associated with high likelihood of incidents occurring	Rationale
Laboratory activities associated with aerosolization (e.g. sonication, homogenisation, centrifugation)	When aerosols are generated by these methods, the likelihood of exposure through inhalation is increased, as is the likelihood of release of these aerosols into the surrounding environment where they might contaminate laboratory surfaces and spread into the community.
Laboratory activities associated with sharps materials	When activities involve work with sharps, the likelihood of percutaneous exposure to a biological agent through a puncture wound is increased.

Low competency of personnel carrying out the work	Low proficiency of personnel in laboratory processes and procedures, through lack of experience, understanding or failure to comply with SOPs and good microbiology practice and procedure (GMPP), can lead to errors in performing the work which are more likely to result in exposure to and/or release of a biological agent.
Highly environmentally stable biological agents	Biological agents that have settled on laboratory surfaces, for example contamination caused by poor technique that allowed settling of aerosol or droplets after release, can be a source of inadvertent exposure as long as they remain stable in the environment, even if the contamination cannot be seen.
Inadequate or poor availability of electrical power, dilapidated laboratory facilities and building systems, malfunctioning equipment, damage from frequent severe weather and access of insects and rodents to the laboratory.	All these factors may result in partial breaches in, or complete failure of, biocontainment systems designed to reduce the likelihood of exposure to and/or release of biological agents.

Table 3: Factors that affect the consequences of an incident if it would be occurred

Factors associated with greater consequences if an incident were to occur	Rationale
Low infectious dose	For infection to occur in an exposed individual, a certain quantity (volume, concentration) of biological agent must be present. Only a small amount of an agent could result in severe consequence, such as a laboratory-associated infection. Furthermore, exposure to larger quantities of that agent (greater than the infectious dose) may result in a more severe presentation of the infection.
High communicability	Even one a single exposure (causing carriage or a laboratory-associated infection) could rapidly spread from laboratory personnel or fomites to many individuals.
High severity and mortality	A laboratory-associated infection following exposure is more likely to cause personnel to become very debilitated, lose their quality of life or die.
Limited availability of effective prophylaxis or therapeutic interventions	The symptoms or outcomes of a laboratory-associated infection cannot be effectively prevented, reduced, or eliminated by a medical intervention. This may also include situations where medical intervention is not available, or emergency response capacity is limited.
Large susceptible population (including laboratory personnel at increased risk)	The larger the susceptible population, the more likely a laboratory-associated infection could rapidly spread and infect larger numbers of people.
Lack of endemicity (i.e. exotic disease)	When an agent is not endemic in the surrounding population, the population is more likely to be susceptible to the agent, leading to an increased likelihood of a laboratory-associated infection spreading to the community.

### 3.1.2.2 Determine the Inherent Risk

The information gathered must then be used to establish how much risk a particular situation presents (i.e. how likely and how severe). Table 4 shows a risk assessment matrix that provides a simplified example of how to assess the relationship between likelihood and consequence in order to determine the inherent risk of exposure to and/or release of a biological agent. In reality, the relationship comparison may include a broader or more complex range of values for determining likelihood and consequence than that which is shown in Table below, but it is a useful tool to demonstrate how the inherent risk can change relative to these independent factors.

Table 4: Risk assessment matrix

		Risk Score				
Likelihood (Given Score)	Almost certain to occur (5)	5	10	15	20	25
	Likely (4)	4	8	12	16	20
	possible (3)	3	6	9	12	15
	Unlikely (2)	2	4	6	8	10
	Rare (1)	1	2	3	4	5
Degree of Consequence (Given Score)		Negligible (1)	Minor (2)	Moderate (3)	Major (4)	Catastrophic (5)
		Consequence				

$$\text{Risk Score} = \text{Consequence grade score} \times \text{likelihood score}$$

#### Likelihood of an exposure or release occurring during the proposed laboratory work

☐ Rare: almost impossible to occur

☐ Unlikely: not very possible to occur

☐ Possible: might occur

☐ Likely: very possible to occur

☐ Almost certain: highly probable to occur

### 3.1.2.3 Establish a Risk Tolerance

Once the inherent risk has been evaluated, it is necessary to determine whether this level is acceptable to allow work to proceed. If it is not, a risk control strategy will be required to reduce and sustainably control those risks appropriately as described in the next step of the risk assessment framework.

Finally, the magnitude and significance level of the risk level (severity) will be evaluated as very high, high moderate or low significance impacts (see table 5 below).

Table 5: Rating and classification of risk level and scoring including action to be taken

Risk Score	Risk level	Description of Risk Level	Actions
1-6	Low	If an incident were to occur, there would be little likelihood that an injury would result.	Acceptance of risk: Residual risk If possible, risk reduction should be further considered, particularly in terms of severity. There are no imminent dangers. Frequent review shall be in place especially changes in procedures, materials or environment.
8-10	Moderate	If an incident were to occur, there would be some chance that an injury requiring First Aid would result.	Take remedial action at the appropriate time. Proceed with care. Additional control is advised. The review must be completed within 30 days.
12-15	High	If an incident were to occur, it would be likely that an injury requiring medical treatment would result.	Controls will need to be in place before the activity is undertaken. High priority remedial action Implement additional (secondary) controls immediately.
16-25	Very high	If an incident were to occur, it would be likely that a permanent, debilitating injury or death would result.	Consider alternatives to doing the activity. Significant control measures will need to be implemented to ensure safety <ul style="list-style-type: none"> <li>• Operation not Permissible</li> <li>• Stop operation &amp; review controls.</li> <li>• If necessary, abort experimentation.</li> </ul>

It is important to acknowledge that there will never be zero risk, unless the work is not conducted at all, so a balance must be carefully managed between conducting the work and ensuring that personnel and the community are as safe as possible from inadvertent exposure to and/or release of biological agents. It is also important to recognize that the work being performed in the laboratory offers considerable benefits to both



human health care and global health security that justifies a certain degree of risk. This “acceptable” level of risk in the laboratory is usually referred to as “risk tolerance”. Determining the risk tolerance is essential in providing a benchmark below which the inherent risk must be reduced for work to be considered safe enough to proceed.

### 3.1.3 Develop a Risk Control Strategy

Once a risk tolerance level has been established, a risk control strategy must be developed for reducing any inherent risks to within an acceptable tolerance level and allow the work to proceed safely. Careful selection of a risk control strategy is required to ensure that risks are prioritized against the available resources with the understanding that a low risk tolerance will require many more resources to address the risk using and maintaining relevant control measures. Risk tolerance, however, must not be raised unnecessarily as a substitute for making resources available to fulfil the necessary risk control strategy and provide the appropriate level of protection. Resources must be made available, or work should not proceed. Table 6 below provides an overview of some of the most common strategies employed for risk control and examples of the risk control measures

Table 6: Strategies for risk reduction

Strategy	Example
Elimination	Eliminate the hazard: <ul style="list-style-type: none"> <li>▪ use an inactivated biological agent,</li> <li>▪ use a harmless surrogate</li> </ul>
Reduction and substitution	Reduce the level of risk: <ul style="list-style-type: none"> <li>▪ substitute with an attenuated or less infectious biological agent,</li> <li>▪ reduce the volume/titre being used,</li> <li>• change the procedure for one that is less hazardous, e.g. polymerase chain reaction rather than culture.</li> </ul>
Isolation	Isolate the hazard: <ul style="list-style-type: none"> <li>▪ Elimination and reduction might not be possible, particularly in a clinical setting, therefore isolate the biological agent(s) (e.g. in a primary containment device).</li> </ul>
Protection	Protect personnel/the environment: <ul style="list-style-type: none"> <li>▪ Use engineering controls (e.g. directional airflow),</li> <li>▪ Use PPE,</li> <li>▪ Vaccinate personnel.</li> </ul>

Compliance	<p>Have administrative controls and effective biosafety programme management in place such as:</p> <ul style="list-style-type: none"> <li>▪ GMPP observed by personnel,</li> <li>▪ Good communication of hazards, risks and controls,</li> <li>▪ Appropriate training,</li> <li>▪ Clear SOPs,</li> <li>▪ An established safety culture.</li> </ul>
------------	--

### 3.1.4 Select and Implement Risk Mitigation Measures

The second fundamental component of the biorisk management model is mitigation. Biorisk mitigation measures are actions and control measures, based on a robust laboratory risk assessment, that are put into place to reduce or eliminate the risks associated with biological agents and toxins. Assessing the risks determines the actions and control measures that will be most effective in reducing and eliminating those particular risks. Often facilities implement unnecessary or inappropriate mitigation measures because a risk assessment has not yet been completed or was completed poorly. In many of those cases, such measures do not reduce the risks, but can rather increase them.

Overall, biorisk mitigation can be divided into five areas of control (figure 2).

- The first category of mitigation control is elimination. Elimination involves not doing the intended work or deciding not to work with a specific biological agent. Elimination provides the highest degree of risk reduction.
- The second category of mitigation control is Substitution which uses a less hazardous material or find a less hazardous way to do the work.
- The third category of mitigation control measures is engineering controls. These control measures are physical changes to workstations, equipment, production facilities, or any other relevant aspect of the work environment that reduces or prevents exposure to hazards. A biosafety cabinet, which comes in three levels of protection, is an example of an engineering control; and even the simple method of locking laboratory doors is an example of security-related engineering controls.
- The fourth category of mitigation control is collectively called administrative controls. These controls are policies, standards, and guidelines used to control risks. Proficiency and competency training for laboratory staff would be considered an administrative control. Displaying biohazard

or warning signage, markings, and labelling, controlling visitor and worker access, and documenting written standard operating procedures are all forms of administrative controls.

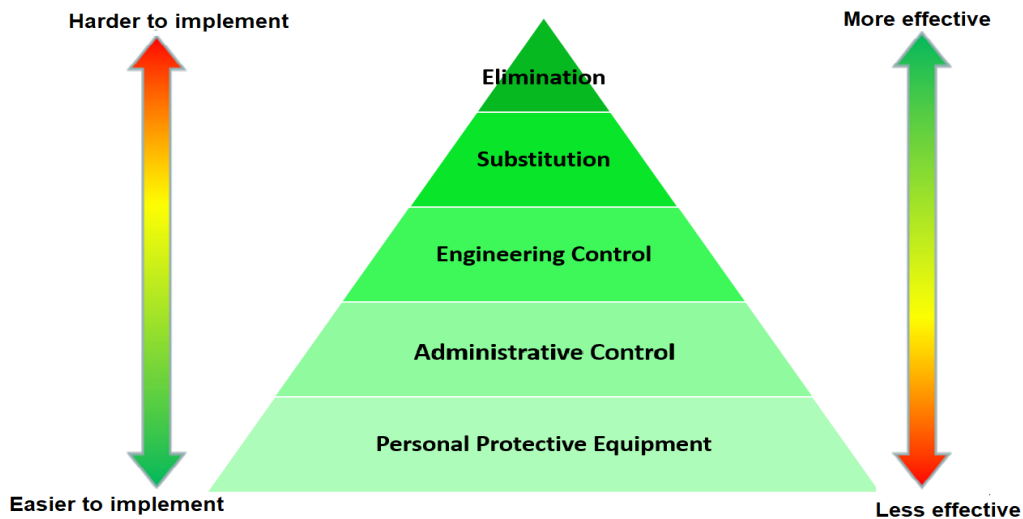

Figure 2: Hierarchy of hazard controls

- The fifth group of mitigation control measures is personal protective equipment (PPE). These are devices worn by workers to protect them against chemicals, toxins, and pathogenic hazards in the laboratory. Gloves, gowns, and respirators are all examples of PPE. PPE is considered the least effective control because it only protects the person who is wearing it, and only if it is used correctly. Its failure or inappropriate use, a rip in the material, or a manufacturing defect, for example, would likely result in exposure.

All five types of mitigation control measures are important and can contribute to reducing biorisks, not one is completely effective at controlling or reducing all risks. The most effective way to mitigate risk is to consider a combination of controls. The concept of a hierarchy of controls describes an order of effectiveness (from most effective to least effective) for mitigation measures and implies that this order should be taken into account when selecting and implementing controls to reduce risk. However, depending on the facility or situation, a mitigation measure lower in the hierarchy may be more effective than one that is higher in the hierarchy.

### 3.2 Review Performance

Performance review represents the third pillar of the biorisk management model. Performance management is a systematic process intended to achieve improved levels of organizational objectives and goals. An

institution's ability to manage and evaluate its performance contributes directly to its development and improvement (Figure 3).

Performance management provides direct evidence that an organization can substantively understand and effectively reduce its operational risks to an acceptable level. A fully functioning biorisk management system will be critically impaired if performance evaluation is absent or only partially implemented. The primary goal of performance evaluations is to ensure that the implemented mitigation measures are indeed reducing or eliminating risks. Performance evaluations also help to highlight biorisk strategies that are not working effectively. Measures that are not effective or are shown to be unnecessary can be eliminated or replaced. It may also be appropriate to reevaluate the overall mitigation strategy.

A risk assessment must therefore be performed and reviewed periodically, at a frequency that corresponds to the risk of the laboratory work. Typically, an annual review is adequate; however, some situations may prompt an ad hoc review, such as a biosafety incident, or feedback from the laboratory personnel on the effectiveness and ease of use of the risk control measures that have been implemented.

## Chapter 4: Core Requirements

Core requirements is the term used to describe a combination of risk control measures that are both the foundation for, and an integral part of, laboratory biosafety. The measures reflect international standards and best practice in biosafety that act as a set of minimum requirements and considerations that are necessary to work safely with biological agents, even where the associated risks are minimal.

These requirements are comprehensive and detailed as they are fundamental to all laboratory facilities. However, where determined by the risk assessment, additional requirements and considerations may be needed for more effective risk control, over and above these core requirements. A major proportion of the work in the laboratory involves handling infectious biological materials. Researcher and Laboratory personnel must have knowledge of safe laboratory procedures and an awareness of potential hazards. The safety standards shall apply to all the staffs who are working in the laboratory and each person has an obligation to protect the health and safety of all by strict observance of the safety regulations identified in this guideline.

### 4.1 Biosafety and Biosecurity Manual

Each facility should establish standard policies and procedures necessary for safe laboratory conduct, handling laboratory hazards, and contingency planning. So that facility should have biosafety and biosecurity, or safety manual. The biosafety and Biosecurity manual should be readily available in work areas as required reading for all employees. The manual should be in accordance with this biosafety and biosecurity guidelines and the facility safety policy.

The manual should be specific for the facility's needs including, but not limited to, the following major categories as applicable:

- Safety policy;
- Risk assessment and management
- Biological hazards;
- Chemical and radiation safety;
- Safety Equipment
- Occupational safety and health including vaccination
- Fire prevention;

- Electrical safety;
- Hazardous waste handling and disposal

In addition, the manual should include detailed instructions for workplace evacuation and the protocol for dealing with an incident. The safety manual should be reviewed and updated at least annually by facility management.

## **4.2 Biohazards Control /Infection Control**

Biohazards control /infection control is the term used to describe a combination of risk control measures that are both the foundation for, and an integral part of, laboratory biosafety. These measures reflect best practices in biosafety that act as a set of minimum requirements and considerations that are necessary to work safely with biological agents, even where the associated risks are minimal. These requirements are comprehensive and detailed as they are fundamental to all laboratory facilities. However, where determined by the risk assessment, additional requirements and considerations may be needed for more effective risk control, over and above these measures. For most procedures used in diagnostic and clinical laboratories, following core laboratory requirements will be sufficient to work safely with most biological agents.

The core requirements include a set of operational and physical elements that, when combined, should be sufficient to control the risks of most procedures with most biological agents in clinical and diagnostic laboratories. All the control measures implemented as part of the core requirements must be appropriately managed in order to help ensure a safe working environment.

## **4.3 Universal Precautions**

Universal precautions (standard precautions) are a standard set of guidelines to prevent the transmission of blood borne pathogens from exposure to blood and other potentially infectious materials. The following standard practices are required for all laboratories handling infectious substances.

- Provide a copy of the safety operations manual for all staff and make sure that its requirements are followed. Review and update the manual regularly.
- Advise personnel to read the safety or operations manual and follow standard practices and procedures and advise on special hazards.
- Handle biological specimens as an infectious substance
- Prohibit eating, drinking, smoking, and storing of food, personal belongings, or utensils, applying

cosmetics, or use of contact lenses in any laboratory.

- Wearing jewelry is not recommended in the laboratory.
- Post signs indicating the above as necessary.
- Limit access to the laboratory to authorized personnel only.
- Keep doors to laboratories closed.
- Cover open wounds, cuts, scratches, and grazes with waterproof dressings.
- Wear gloves for all procedures that might involve direct skin contact with biohazardous material or infected animals.
- Wash hands after gloves have been removed, before leaving the laboratory, and at any time after handling materials known or suspected to be contaminated.
- Wear protective laboratory coats properly fastened to prevent contamination or soiling of street clothes.
- Do not wear protective laboratory clothing outside laboratory areas; do not store laboratory clothing in contact with street clothing.
- Perform all procedures carefully to minimize splashes and aerosols.
- Never pipette any substance by mouth in any laboratory.
- Use eye and face protection (eye goggles or face shield) where there is a potential risk of exposure to splashes of microorganisms or other hazardous materials.
- Decontaminate work surfaces at least once daily and after any spill of viable material.
- Strictly limit the use of needles, syringes, and other sharp objects. Use needles and syringes only for parenteral injection and aspiration of fluids from laboratory animals. Dispose of them in puncture-resistant sharps containers.
- Keep laboratories clean and tidy. Separate paperwork and report writing, journals and books from biohazardous materials working areas.
- Decontaminate all contaminated materials, solid or liquid, and all cultures before disposal by an appropriate decontamination method such as autoclaving.
- If a known or suspected exposure occurs, decontaminate clothing before washing.
- Use leak-proof containers for the transport of infectious materials within facilities (e.g., between laboratories in the same facility).
- Report to the laboratory supervisor immediately all spills, accidents or exposure to infectious

materials and losses of containment. Keep written records of all incidents.

- Maintain an effective rodent and insect control program.

## **4.4 Good Microbiological Practices and Procedures (GMPP)**

It is essential that laboratory personnel are trained and proficient in GMPP to ensure safe working practices. Without GMPP, risk cannot be controlled sufficiently, even if other physical control measures are in place. Additional operational practices and procedures may be required for work where higher risks involved. GMPP includes general behaviours, best practices, and technical procedures which together help to protect both the laboratory worker and the work itself from exposure to and/or release of biological agents.

### **4.4.1 Best Practices**

Best practices describe behaviours that are essential to facilitate safe work practices and control biological risks. Examples of laboratory best practices are outlined below.

- Never storing food or drink, or personal items such as coats and bags in the laboratory.
- Never put materials, such as pens, pencils, or gum in the mouth while inside the laboratory, regardless of having gloved hands or not.
- Thoroughly washing hands, preferably with warm running water and soap, before and after, any laboratory activities performed.
- Ensure open flames or heat sources are never placed near flammable supplies and never left unattended.
- Cover should be placed over any cuts or broken skin prior to entering the laboratory.
- Ensure prior to entry into the laboratory, supplies of laboratory equipment and consumables, including reagents, PPE, and disinfectants, are sufficient and appropriate for the activities being performed.
- Ensure supplies are stored appropriately and safely to reduce the chance of accidents and incidents such as spills, trips, or falls for laboratory personnel.
- Protect written documents from contamination using barriers particularly those that may need to be removed from the laboratory.
- Ensure work is performed with care, in a timely manner and without rushing.
- Avoid working when you are fatigued.



- Keep the work area tidy, clean, and free of clutter and materials not necessary for the work being done.
- Prohibit the use of earphones, which can distract personnel and prevent equipment or facility alarms from being heard.
- Cover or remove appropriately any jewellery which could tear glove material, easily become contaminated or act as a fomite for infection. If worn regularly, cleaning and decontamination of the jewellery or spectacles should be considered.
- Refrain from using mobile electronic devices (e.g. mobile telephones, tablets, laptops, flash drives, memory sticks, cameras and/or other portable devices including those used for DNA/RNA sequencing) when not specifically required for the laboratory procedures being carried out.

#### **4.4.2 Hand Washing**

- Follow standard hand washing procedure.
- Wash hands immediately before wearing and after removing gloves
- Use running water to rinse hands.
- If tap water is not available, use a bucket with tap or pour water with a jug.
- Use suitable antiseptics. About 1 teaspoonful of the antiseptic can be used to rub hands until dry (15-30 seconds).

#### **4.4.3 Technical Procedures**

Technical procedures are a special subset of GMPP which relate directly to controlling risks through safe conduct of laboratory techniques. These technical procedures, when executed correctly, allow work to be performed in a manner that minimizes the likelihood of cross-contamination.

#### **4.4.4 Avoiding Inhalation of Biological Agents**

Use good techniques to minimize the formation of aerosols and droplets when manipulating samples. This includes refraining from forcibly expelling substances from pipette tips into liquids, over-vigorous mixing, and carelessly flipping open tubes.

- Avoid introducing loops or similar instruments directly into an open heat source (flame) as this can cause spatter of infectious material. Where possible, use disposable transfer loops, which do not need to be re-sterilized.

#### **4.4.5 Avoiding Ingestion of Biological Agents and Contact with Skin and Eyes**

- Wear disposable gloves at all times when handling samples known or reasonably expected to contain biological agents. Disposable gloves should not be reused.
- Avoid contact of gloved hands with the face.
- Remove gloves aseptically after use and wash hands.
- Shield or otherwise protect the mouth, eyes, and face during any operation where splashes may occur, such as during the mixing of disinfectant solutions.
- Secure hair to prevent contamination.
- Cover any broken skin with a suitable dressing.
- Prohibit pipetting by mouth.

#### **4.4.6 Avoiding Injection of Biological Agents**

- Wherever possible, replace any glassware with plastic-ware.
- For work needing scissors, use scissors with blunt or rounded ends in preference to those with pointed ends.
- If glassware must be used, check it on a regular basis for integrity and discard it if anything is broken, cracked or chipped.
- Minimize the risk associated with the use of syringes or with needles by using blunt syringe needles, alternative devices or engineered sharp safety devices where possible.
- Never use syringes with needles as an alternative to pipetting devices.
- Never re-cap, clip or remove needles from disposable syringes.
- Dispose of any sharp's materials in puncture-proof or puncture-resistant containers fitted with sealed covers. Disposal containers must be puncture-proof/-resistant, must not be filled to capacity (three-quarters full at most), must be never reused, and must not be discarded in landfills.

#### **4.4.7 Biological Spill Response**

Spill kits, including disinfectant, must be easily accessible to personnel. Depending on the size, location, concentration and/or volume of the spill, different protocols may be necessary. Written procedures for cleaning spills must be developed for the laboratory and followed by suitably trained personnel, see annex 2 for spill management.

If a spill occurs where there is a high inherent risk (due to a large formation of aerosols, a large volume/high concentration of liquid spilt, and/or high pathogenicity of the biological agent involved) the following protocol should be followed:

- Personnel must immediately vacate the affected area.
- Exposed persons should be referred for medical evaluation.
- The room containing the spill should not be entered for a length of time that allows aerosols to be carried away and heavier particles to settle. If the laboratory does not have a central air exhaust system, entrance should be delayed for longer.
- Signs must be posted indicating entry is forbidden.
- The laboratory supervisor and the biosafety officer must be informed as soon as possible after the event has occurred.
- After the necessary amount of time has elapsed, decontamination must proceed, depending on the size of the spill, this may require help or supervision
- Suitable protective clothing and respiratory protection may be needed for the spill clean-up.

#### **4.5 Preventing Dispersal of Biological Agents**

- Discard samples and cultures for disposal in leak-proof containers with tops appropriately secured before disposal in dedicated waste containers.
- Place waste containers, preferably unbreakable (e.g. plastic, metal), at every workstation.
- Regularly empty waste containers and securely dispose of waste.
- Decontaminate work surfaces with a suitable disinfectant at the end of the work procedures and if any material is spilled.

- When disinfectants are used, ensure the disinfectant is active against the agents being handled and is left in contact with waste materials for the appropriate time, according to the disinfectant being used.
- Decontaminate all infectious material before disposal.

## **4.6 Personnel Competence and Training**

Human error and poor technical skills can compromise the best safeguards. Thus, competent, and safety-conscious laboratory workers, who are well informed on how to recognize and control laboratory risks, are essential for the prevention of laboratory-associated infections and/or other incidents.

## **4.7 Facility Design**

The facility design features listed below are core requirements for biosafety for all laboratories handling biological agents. The facility design and facilities required for each biosafety level laboratories described in chapter 5 principles of biosafety.

- Ample space must be provided for the safe conduct of laboratory work and for cleaning and maintenance.
- Designated hand-washing basins must be provided in each laboratory room, preferably close to the exit door.
- The laboratory must be a restricted-access area. Laboratory entrance doors should have vision panels (to avoid accidents during opening), appropriate fire ratings and preferably be self-closing.
- Doors must be appropriately labelled with the international biohazard warning symbols wherever biohazardous materials are handled and stored.
- Laboratory walls, floors and furniture must be smooth, easy to clean, impermeable to liquids and resistant to the chemicals and disinfectants normally used in the laboratory.
- Laboratory bench tops must be impervious to water and resistant to disinfectants, acids, alkalis, organic solvents, and moderate heat.
- Laboratory furniture must be fit for purpose. Open spaces between and under benches, cabinets and equipment must be accessible for cleaning.
- Laboratory lighting (illumination) must be adequate for all activities.

- Laboratory ventilation where provided to ensure airflows do not compromise safe working. Consideration must be given to resultant airflow speeds and directions, and turbulent airflows should be avoided; this applies also to natural ventilation.
- Laboratory storage space must be adequate to hold supplies for immediate use to prevent clutter on bench tops and in walkways. Additional long-term storage space, conveniently located outside of the laboratory room/space, should be considered.
- Space and facilities must be provided for the safe handling and storage of chemicals and solvents, radioactive materials, and compressed and liquefied gases if used.
- Facilities for storing food and drink, personal items, jackets, and outerwear must be provided outside the laboratory.
- Facilities for eating and drinking must be provided outside the laboratory.
- First-aid facilities must be readily accessible and suitably equipped/stocked and staff must be aware on how to use the first aid kit.
- Availability of emergency shower and eye wash station.
- Appropriate methods for decontamination of waste, for example, disinfectants and autoclaves, must be available in proximity to the laboratory.
- Waste management must be considered in the facility design. Safety systems must cover fire, electrical emergencies and emergency/incident response facilities based on risk assessment.
- There must be a reliable and adequate electricity supply and lighting to permit safe exit.
- Emergency situations must be considered in the design as indicated in the local risk assessment and should include the geographical/meteorological context.
- Fire security and flood risk must be considered.

## **4.8 Safe Handling Biological Hazardous Specimens**

Improper collection, transport, processing, and storage of biological specimens will create a risk of infection to the personnel involved, and the community. Safe handling of biological specimens begins during collection. When not properly packaged, infectious substances received in the laboratory can pose a safety risk to personnel. The following subsections describe the risk control measures that should be in place when collecting, receiving, storing, and inactivating specimens as part of the core requirements for biosafety. Thus, the laboratory shall handle biological hazardous specimens safely and procedures shall be prepared and implemented.

### **4.8.1 Collection of Clinical Specimen**

There are different types of specimens collected for different purpose such as for laboratory diagnosis and research. The precautions that shall be taken during specimen collection include but not limited to the following:

- Laboratory personnel performing specimen sampling should be trained on sample management in consideration of safety and decontamination techniques.
- The personnel should use PPE during collection.
- The PPE material should be as per the patient's clinical condition.
- The material type used for specimen collection should be specific and standard as per the specimen type.
- Breakage resistance plastic container for specimen collection should be used and securely capped to prevent leakage and spread of infectious agents.
- The collected specimen should be handle based on the protocol set for specimen type.
- Do not recap, bend, or break needles by hand or remove needles from disposable syringes.
- Used material for specimen collection should be segregated and disposed based on the waste type.
- Sharp materials should be discarded in to puncture proof or puncture resistance container fitted with covers.
- Specimen containers shall preferably be plastic, robust and should not leak when the cap or stopper is correctly applied.

### **4.8.2 Receiving Specimens**

A specimen received by the laboratory shall be accompanied by sufficient information to identify what it is, when and where it was taken or prepared, and which tests and/or procedures (if any) are to be performed.

Personnel unpacking and receiving specimens must be adequately trained in:

- awareness of the hazards involved,
- how to adopt necessary precautions according to GMPP described above,
- how to handle broken or leaking containers to prevent exposure to biological agents, and
- how to handle spills and use disinfectants to manage any contamination.

Specimens must be observed on receipt to make sure they have been packaged correctly according to shipping requirements and that they are intact. Where breaches of packaging are observed, the package should be

placed in an appropriate sealable container. The breach in packaging should be reported to the sender and couriers.

- Specimen request or specification forms must be placed separately, preferably in waterproof envelopes, away from potential damage or contamination. Laboratories that receive large numbers of specimens should consider designating a room or area specifically for receiving specimens.

### **4.8.3 Specimens Processing**

Each facility shall follow the following safety measures during specimens processing:

- Specimen processing should be done by only trained staff.
- Before processing any specimen prepare fresh disinfectant solution for decontamination of spill and equipment during processing.
- Check any previously disposed biological waste and sample are segregated and incinerated before processing.
- Check any safety equipment are working properly.
- Prepare and arrange working area.
- Use appropriate personal protective equipment.
- Cover the working area with absorbent material to avoid dispersion of infectious materials dropped from a pipette and spray it with suitable disinfectant that should not be disposed as infectious waste after use.
- Splashes and aerosols should be avoided or minimized by using good laboratory techniques.
- Contaminated pipettes should be completely submerged in a suitable disinfectant contained in an unbreakable container. They should be left in the disinfectant for the appropriate length of time before disposable.
- Place discarded specimen tubes containing body fluids and culture, etc. (with caps replaced) in suitable leak-proof containers for autoclaving and/or incineration.
- Avoid aspirating of blood or serum from container using syringes fitted with hypodermic needle.
- A pipetting aid must always be used. Pipetting by mouth must be prohibited.
- When opening tubes with specimens, grasp the stoppers through a piece of paper or gauze soaked with disinfectant to prevent splashing.
- Working areas must be decontaminated with a suitable disinfectant at the end of each working period.

- When a risk group III and IV organism containing samples are centrifuged, a securely capped tube and enclosing centrifuge must be used or use the centrifuge inside a biosafety cabinet class III to protect against infectious aerosols and dispersed particles.
- In case of accidental injury with a contaminated needle, the following procedure must be followed:
  - ✓ Remove gloves and dispose of properly.
  - ✓ Encourage bleeding but do not squeeze.
  - ✓ Wash the area with soap and water for 5 minutes.
  - ✓ Record the patient's name and card number for further investigation of exposure risk level. Follow the national guidelines for post-exposure prophylaxis.

#### **4.8.4 Specimen Storage**

Each facility shall ensure the following measures during specimen's storage. Specimens must be stored in containers that are:

- made of adequate strength, integrity, and volume to contain the specimen,
- leak-proof when the cap or stopper is correctly applied,
- made of plastic (whenever possible),
- free of any biological material on the outside of the packaging,
- correctly labelled, marked and recorded to facilitate identification, and
- made of an appropriate material for the type of storage required.
- Care must be taken when storing specimens in liquid/vapour phase nitrogen.
- Only tubes specifically noted by the manufacturer as being suitable for liquid nitrogen cryogenic storage should be used to reduce the likelihood of breakage on removal from liquid nitrogen.
- It is important to note that liquid and vapour can enter improperly sealed or cracked tubes and can rapidly expand on removal of the tube from storage; this can lead to breakage and/or explosion. Thermal protective gloves and apron should be worn when accessing liquid nitrogen storage and a visor should be worn for splash protection.

#### **4.9 Disposal of Needles and Other Sharp Instruments**

Each facility shall follow the following safety measures during disposable sharp materials:

- Whenever possible avoid use of needles and sharp instruments.
- After use, never recap, clip, or remove hypodermic needles from disposable syringes.
- Place the complete assembly in a sharps disposal puncture-resistant container. In resource limited



settings, a heavy cardboard box, a plastic bottle, or a tin with a lid can be used.

- When the container is three-quarters full, remove it from the area of work for disposal wearing heavy-duty gloves. Close the container tightly by cupping, plugging, or taping.
- Dispose by burning, encapsulation or burying (see waste management).
- Remove heavy duty utility gloves and wash hands. If hands are not visibly soiled, use 5ml (1 tablespoon of antiseptic) to rub the hands until dry.

#### **4.10 Aspiration from or Inoculation into Sterile Containers**

Each facility shall follow the following safety measures during the aspiration:

- The use of syringes and needles to aspirate material from containers such as tubes containing blood or serum, blood culture bottles, anaerobic bottles.
- To inoculate this material into such containers is a high-risk procedure that is responsible for many needle stick injuries.
- Use exceptional care with these procedures.
- Where affordable, use protective shields which are available in the market.

#### **4.11 Suction**

The disposal of infected liquids by suction requires extreme care. However each facility shall follow the following safety measures during performing suction:

- Use two or more bottles of sodium hypochlorite disinfectant (bleach) in series.
- Never allow the liquid to be sucked directly into the vacuum line.

#### **4.12 Storage of Ampoules Containing Infectious Material**

Each facility shall follow the following safety measures during the storage:

- Never immerse ampoules containing infectious material in liquid nitrogen because cracked or imperfectly sealed ampoules may break or explode on removal.
- If very low temperatures are required, store ampoules only in the gaseous phase above the liquid nitrogen. Otherwise, store infectious materials in mechanical deep freeze cabinets or on dry ice.
- Wear eye and hand protection when removing ampoules from cold storage.
- Disinfect the outer surfaces of ampoules stored in these ways when removing the ampoules from storage.

### **4.13 Opening of Ampoules Containing Lyophilized Infectious Material**

Care should be taken when ampoules of freeze-dried material are opened, as the contents may be under reduced pressure and the sudden in-rush of air may disperse some of the materials into the atmosphere. The following procedures are recommended for opening ampoules:

- Ampoules should be opened in a biological safety cabinet, if available.
- First decontaminate the outer surface of the ampoule.
- Hold the ampoule in alcohol-soaked cotton to protect hands before breaking it with a file.
- Remove the top gently and treat it as contaminated material.
- If there is a cotton or cellulose plug in the ampoule, remove it with sterile forceps.
- Add liquid for resuspension slowly to avoid frothing.

### **4.14 Special Consideration for SARS-CoV-2 Virus Specimen Collection and Testing**

The transmission of SARS-CoV-2 in healthcare settings has been a matter of concern during the COVID-19 pandemic, especially early in the pandemic in 2020. Among hospitalized confirmed COVID-19 patients, it has been estimated that up to 41% were infected in healthcare settings. The incidence of infection among health workers has been reported to be up to 49.6%. As SARS-CoV-2 continues to circulate widely, healthcare facilities remain a high-risk transmission setting where patients at risk of severe COVID-19 are admitted. Hence, it is critical to maintain infection prevention control measures, including appropriate PPE use and physical distancing. The WHO continues to advise that the current recommended IPC measures be reinforced and continue to be stringently implemented in healthcare facilities. Thus, due to the current COVID-19 pandemic, safety standard practices required for SARS-CoV-2 specimen collection, handling, storage, and testing have been given special consideration in this biosafety and biosecurity guideline.

#### **4.14.1 Standard and Transmission-Based Precautions**

Based on the available evidence, the COVID-19 virus is transmitted between people through close contact and droplets, not by airborne transmission. The people most at risk of infection are those who are in close contact with a COVID-19 patient, who collect specimen or performing test on COVID-19 specimen. Since every person could be potentially infected with COVID 19 virus that could be transmitted in the healthcare setting. In order to prevent and control the COVID 19 virus transmission, the following elements of standard precautions or preventive and mitigation measures should be implemented:

- Performing hand hygiene frequently with an alcohol-based hand rub if your hands are not visibly dirty or with soap and water if hands are dirty.
- Avoiding touching your eyes, nose, and mouth.
- Practicing respiratory hygiene by coughing or sneezing into a bent elbow or tissue and then immediately disposing of the tissue.
- Wearing a medical mask if you have respiratory symptoms and performing hand hygiene after disposing of the mask, maintaining social distance (a minimum of 1 metre) from persons with respiratory symptoms.
- Use appropriate personal protective equipment (PPE) and proper donning (putting on), doffing (taking off), and disposal of PPE is crucial.

#### **4.14.2 Personal Protective Equipment**

Health facilities should select appropriate PPE and provide it to health professional in accordance. Health professional must receive training on how to use PPE.

#### **4.14.3 Safe Collection of Specimens for SAR-CoV2**

When collecting COVID- 19 virus diagnostic respiratory specimens such as nasopharyngeal (NP) swab, oropharyngeal (OP) swab, bronchoalveolar lavage, tracheal aspirate, sputum, pleural fluid, and lung biopsy from a patient with possible COVID-19, the following should be implemented.

- Specimen collection should be performed in a normal examination room or separate room with the door closed.
- Health Professionals who are specimen collectors should wear the following PPE
  - N95 Mask or higher-level respirator
  - Eye protection (Goggles or Face shield)
  - Gloves
  - Gown/Apron
- The number of health professionals present during the specimen collection should be limited to only those essential for patient care and collection support.
- Clean and disinfect specimen collection room surfaces promptly using disinfectant that appropriate for SARS-CoV-2 for appropriate contact times as indicated on the product's label

- PPE should be removed properly after finalizing specimen collection as described at Annex 3 PPE Doffing Procedures.

#### **4.14.4 Packaging and Shipping of Specimens**

- Transport of SARS-CoV-2 specimens within country (from one facility to another facility or region), specimens must be packaged, shipped, and transported in triple packaging system as assigned United Nations (UN) numbers 3373 (UN 3373) Biological Substance, Category B in accordance with the current edition of the International Air Transport Association (IATA) Dangerous Goods Regulations
- If shipping samples to testing laboratories;
  - The specimens should ship without delay,
  - Store specimens at 2-8°C, and ship on ice pack. If a delay in shipping will result in receipt more than 72 hours after collection, store specimens at -70°C or below.
- All materials transported within and between laboratories (the same facility) should be placed in a secondary container, to minimize the potential for breakage or a spill. An example includes transfer of materials from the BSC to an incubator and vice versa. Specimens leaving the BSC should be surface decontaminated.

#### **4.14.5 Storage of Specimens**

- All specimens should be stored at 2-8°C for up to 72 hours after collection. If a delay in testing or shipping is expected, specimens should be stored at -70°C or below.

#### **4.14.6 Biosafety Practice at SARS-CoV-2 Virus Laboratory**

All laboratories should perform a site-specific and activity-specific risk assessment to identify and mitigate risks. Risk assessments and mitigation measures are dependent on:

- The procedures performed.
- Identification of the hazards involved in the process and/or procedures.
- The competency level of the personnel who perform the procedures.
- The laboratory equipment and facility.
- The resources available.

- Follow Standard Precautions when handling clinical specimens, all of which may contain potentially infectious materials. Standard Precautions include hand hygiene and the use of personal protective equipment (PPE).
- Follow routine laboratory practices and procedures for decontamination of work surfaces and management of laboratory waste.
- Routine laboratory procedures, including non-propagative diagnostic work and PCR analysis non-culture-based diagnostic laboratory work, and PCR analysis on clinical specimens from patients who are suspected or confirmed to be infected with novel coronavirus, should be conducted adopting practices and procedures described for conventional clinical and microbiology laboratories as described below as “core requirements”
- However, all manipulations of potentially infectious materials, including those that may cause splashes, droplets, or aerosols of infectious materials (e.g. loading and unloading of sealed centrifuge cups, grinding, blending, vigorous shaking or mixing, sonic disruption, opening of containers of infectious materials whose internal pressure may be different from the ambient pressure), however, should be performed in appropriately maintained and validated BSCs or primary containment device by personnel with demonstrated capability.
- Routine diagnostic testing of specimens, such as the following activities, can be handled in a BSL-2 laboratory using Standard Precautions
- Initial processing (before inactivation) of all specimens, including those for sequencing and NAAT, should take place in an appropriately maintained and validated/certified BSC or primary containment device.
- All technical procedures should be performed in a way that minimizes the generation of aerosols and droplets.
- Although appropriate personal protective equipment (PPE) is determined by a detailed risk assessment, WHO and CDC recommend personnel working on manipulation of respiratory samples or perform COVID 19 testing should be worn the following PPE
  - N95 mask
  - Gown

- Gloves
- Eye protection (if risk of splash)
- During wearing PPE you should follow proper PPE donning procedures (see annex 3)
- For procedures with a high likelihood to generate aerosols or droplets, use either a certified Class II Biological Safety Cabinet (BSC) or additional precautions to provide a barrier between the specimen and personnel; additional precautions include personal protective equipment (PPE), such as mask or face shield, or other physical barriers, like a splash shield; centrifuge safety cups; and sealed centrifuge rotors to reduce the risk of exposure to laboratory personnel.
- Appropriate disinfectants with proven activity against COVID- 19 viruses should be used for the recommended contact time, at the correct dilution and within the expiry date after the working solution is prepared
- After finalizing any activities, PPE should be removing or doffing properly as described at Annex 3 PPE Doffing Procedures.

#### **4.14.7 Precautions When Performing Aerosol Generating Procedures**

- Some procedures performed on patients with known or suspected COVID-19 could generate infectious aerosols.
- The following laboratory procedures have been associated with the generation of infectious aerosols and droplets: centrifugation, pipetting, vortexing, mixing, shaking, sonicating, removing caps, decanting liquids, aliquoting and loading specimens, aspirating and transferring blood and body fluids, spilling specimens, and cleaning up spills. So procedures that pose such risk should be performed cautiously and avoided if possible.
- If performed, the following should occur:
  - Health professionals performing procedures should wear
    - N95 Mask or higher-level respirator,
    - Eye protection,
    - Gloves
    - Gown

- The number of professionals present during the procedure should be limited to only those essential for procedure support.
- Clean and disinfect procedure room surfaces promptly using appropriate disinfectants

#### **4.14.8 Disinfectants and Decontamination**

##### **4.14.8.1 Disinfectants**

According to WHO recommendation, including sodium hypochlorite (bleach 0.1% for general surface disinfection and 1% for disinfection of blood spills); 62-71% ethanol; 0.5% hydrogen peroxide; quaternary ammonium compounds; and phenolic compounds, if used according to the manufacturer's recommendations.

##### **4.14.8.2 Decontamination**

Decontaminate work surfaces and equipment with appropriate disinfectants. Use disinfectants with label claims to be effective against enveloped viruses. Follow manufacturer's recommendations for use, such as dilution, contact time, and safe handling.

#### **4.14.9 Decontamination and Cleaning Utilities and Surfaces Contaminated with COVID 19 Virus**

WHO recommendations are to clean utility such as gloves or heavy duty, reusable plastic aprons with soap and water and then decontaminate them with 0.5% sodium hypochlorite solution after each use. Sodium hypochlorite at 0.5% equivalent should be used for disinfecting surfaces.

##### **4.14.10 Waste Management**

Handle laboratory waste from testing suspected or confirmed COVID-19 patient specimens as all other biohazardous waste in the laboratory. Currently, there is no evidence to suggest that this laboratory waste needs any additional packaging or disinfection procedures and the general practices healthcare waste management described in chapter 10.

## Chapter 5: Principles of Biosafety

A fundamental objective of any biosafety program is the containment of potentially hazardous biological agents and toxins. Understanding the principles of biosafety, the use of well-executed risk assessments, and the adherence to the microbiological practices, containment, and facility safeguards will continue to contribute to a safer and healthier working environment for laboratory staff, coworkers, and the community and environment. This chapter describes the important components of biosafety such as containment, biosafety levels and organisms risk group,

### 5.1 Containment

The term Containment/biocontainment describes a combination of primary barriers (safety equipment) and secondary barriers (facility design and construction), facility practices and procedures, and other safety equipment, including PPE, for managing the risks associated with handling and storing hazardous biological agents and toxins in a laboratory environment. The purpose of containment is reduce the risk of exposure to staff and the unintentional release of hazardous biological agents or toxins into the surrounding community and environment and the three elements of containment such as safety equipment, facility designs and construction and facility practice and procedures described below. Work is assigned a biosafety level based on the pathogens and operations to be performed, the documented or suspected routes of transmission for the agent, and the laboratory functions and activities. However, final determination on the combination of containment measures required to address the relevant biosafety risk present at a facility should be based on a comprehensive biosafety risk assessment.

#### 5.1.1 Safety Equipment (Primary Barriers)

Primary Barriers or primary containment is defined as physical containment measure(s) placed directly at the level of the hazard. Safety equipment such as biological safety cabinets (BSCs, PPE), enclosed containers, and other biosafety controls are designed to protect personnel, the surrounding community, and the environment from possible exposure to hazardous biological agents and toxins. Primary barriers can function to either provide containment (e.g., BSCs) or direct personal protection from the hazardous biological agents and toxins used.



### **5.1.2 Facility Design and Construction (Secondary Barriers)**

The design and construction of the laboratory facility provide a means of secondary containment of hazardous biological agents and toxins. The secondary barriers, together with other biosafety controls, help provide protection of personnel, the surrounding community, and the environment from possible exposure to hazardous biological agents and toxins. When the risk of infection by aerosol or droplet exposure is present, higher levels of secondary containment and multiple primary barriers may be used in combination with other controls to minimize the risk of exposure to personnel and the unintentional release into the surrounding community or the environment.

### **5.1.3 Facility Practices and Procedures**

Established facility-specific best practices and procedures are essential to support the implementation and sustainability of a successful biosafety program. Persons working in facilities that handle and store hazardous biological agents and toxins must be able to properly identify all potential hazards, be trained and proficiency in necessary safe practices and procedures. Management and leadership are responsible for providing and arranging the appropriate training of all personnel based on their functional roles and responsibilities in support of the biosafety program. Strict adherence to documented laboratory best practices and procedures is an essential element of a robust biosafety program since failure to follow the established procedures could result in an accidental exposure to personnel or unintentional release of hazardous biological agents and toxins into the surrounding community or the environment.

## **5.2 Biosafety Levels**

There are four biosafety levels (BSL) which consist of a combination of laboratory design, laboratory practices, facilities, equipment, and waste management for use in microbiology, clinical and research laboratories depending on the increasing danger of microorganisms handled. Diagnostic and healthcare laboratories must all be designed for Biosafety Level 2 and above. The four levels are organized in ascending order by the degree of protection provided to personnel, the environment, and the community. Special practices address any unique risks associated with the handling of agents requiring increasing levels of containment. Appropriate safety equipment and laboratory facilities enhance worker and environmental protection.

Selection of the appropriate combinations to safely conduct the work should be based upon a comprehensive facility specific risk assessment that documents the properties of the biological agents and toxins to be

used, potential host characteristics, potential routes of infection, and the laboratory work practices and procedures conducted or anticipated to be used in the future.

### **5.2.1 Biosafety Level 1**

Biosafety Level 1 (BSL-1) standard practices, safety equipment, and facility specifications are generally appropriate for undergraduate, secondary educational training and teaching laboratories and for other laboratories that work with defined and characterized strains of viable biological agents not known to consistently cause disease in healthy adult humans.. BSL-1 represents a basic level of containment that relies on standard, microbiological best practices and procedures with no special primary or secondary barriers, other than a door, a sink for handwashing, and non-porous work surfaces that are cleanable and easy to decontaminate. Biosafety Level 1 is the lowest level of containment.

- It relies entirely on standard microbiological practices with no special barriers. This is appropriate for those working with microorganisms that are not known to cause disease in humans (Risk group 1 e.g. *Bacillus subtilis*).
- Work is done on open bench tops; special containment equipment or facility design is not required.

The recommended standard practices, safety equipment, and facility specifications for BSL-1 are described below.

#### **5.2.1.1 Laboratory Practice and Procedures**

- The laboratory supervisor enforces the institutional policies that control safety in and access to the laboratory.
- The laboratory supervisor ensures that laboratory personnel receive appropriate training regarding their duties,
- Wear gloves to protect hands from exposure to hazardous materials
- Wash hands after working with potentially hazardous materials and before leaving the laboratory
- Eating, drinking, smoking, handling contact lenses, applying cosmetics, and storing food for human consumption are not permitted in laboratory areas. Food is stored outside the laboratory area.
- Mouth pipetting is prohibited. Mechanical pipetting devices are used.
- Safe handling of sharps, such as needles, scalpels, pipettes, and broken glassware
- Perform daily decontamination
- Decontamination after spill not required (unless creating aerosols)
- Biosafety Manual should be available

### **5.2.1.2 Safety Equipment**

- Special containment devices or equipment, such as biosafety cabinets (BSCs), are not generally required.
- Protective laboratory coats, gowns, or uniforms are worn to prevent contamination of personal clothing.
- Protective eyewear is worn by personnel when conducting procedures that have the potential to create splashes and sprays of microorganisms or other hazardous materials.

### **5.2.1.3 Laboratory Facility Design and Facilities**

- Laboratories have doors for access control.
- Laboratories have a sink for handwashing.
- An eyewash station is readily available in the laboratory.
- The laboratory is designed so that it can be easily cleaned.
- Laboratory furniture can support anticipated loads and uses.
- Benchtops are impervious to water and resistant to heat, organic solvents, acids, alkalis, and other chemicals.
- Chairs used in laboratory work are covered with a non-porous material that can be easily cleaned and decontaminated with appropriate disinfectant.
- Laboratory windows that open to the exterior are fitted with screens.

## **5.2.2 Biosafety Level 2**

Biosafety Level 2 (BSL-2) standard practices, safety equipment, and facility specification are applicable to laboratories in which work is performed using a broad- spectrum of biological agents and toxins that are associated with causing disease in humans of varying severity. With good practices and procedures, these agents and toxins can generally be handled safely on an open bench, provided the potential for producing splashes and aerosols is low.

The primary routes of exposure to personnel working with these types of biological agents and toxins related to accidents including exposure via the percutaneous or mucosal routes and ingestion of potentially infectious materials. Extreme caution should be taken with contaminated needles and other sharp materials.

BSL 2 is generally applied to work done with agents associated with human diseases of varying severity and hepatitis B virus, HIV, and Salmonella are examples of the biological agents that meet these criteria.

The following sections describe the recommended standard practices, safety equipment, and facility specifications for BSL-2.

#### **5.2.2.1 Laboratory Facility Design and Facilities**

- Provide sufficient space for safe conduct of laboratory work and for cleaning and maintenance.
- Walls, ceilings and floors should be smooth, easy to clean and resistant to chemicals.
- Laboratory doors should be self-closing and have locks and the size of the door should be enough to let in and out large laboratory equipment.
- The emergency exit door should be easy to open from inside to outward by pushing and self-closing
- Laboratories have a sink for handwashing. It should be located near the exit door.
- An eyewash station is readily available in the laboratory.
- The laboratory is designed so that it can be easily cleaned.
- Carpets and rugs in laboratories are not appropriate.
- Spaces between benches, cabinets, and equipment are accessible for cleaning.
- Laboratory furniture can support anticipated loads and uses.
  - Benchtops are impervious to water and resistant to heat, organic solvents, acids, alkalis, and other chemicals.
  - Chairs used in laboratory work are covered with a non-porous material that can be easily cleaned and decontaminated with appropriate disinfectant.
- Laboratory windows that open to the exterior are not recommended. However, if a laboratory does have windows that open to the exterior, they are fitted with screens.
- Illumination is adequate for all activities and avoids reflections and glare that could impede vision.
- Vacuum lines in use are protected with liquid disinfectant traps and in-line High-Efficiency Particulate Air (HEPA) filters or their equivalent. Filters are replaced, as needed, or are on a replacement schedule determined by a risk assessment.
- There are no specific requirements for ventilation systems. However, the planning of new facilities considers mechanical ventilation systems that provide an inward flow of air without recirculation to spaces outside of the laboratory.

- BSCs and other primary containment barrier systems are installed and operated in a manner to ensure their effectiveness.
- Storage space must be adequate to hold supplies for immediate use. Additional long term storage space, conveniently located outside the laboratory working areas, should also be provided.

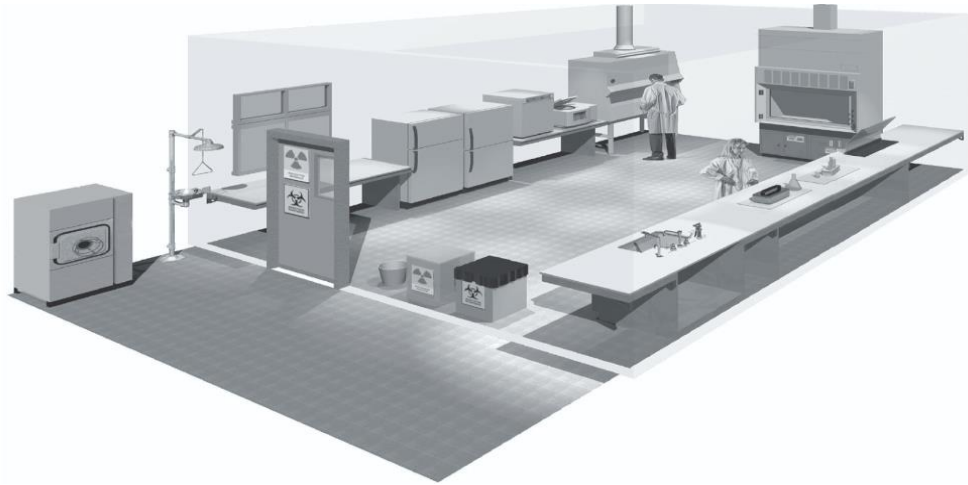

Figure 3: A typical design of biosafety level 2 laboratory (WHO 2004)

#### **5.2.2.2 Laboratory Practice and Procedures**

- The laboratory supervisor enforces the institutional policies that control safety in and access to the laboratory.
- Prepare a safety manual specific to the facility in consultation with the facility director and appropriate safety professionals.
- Make sure that lab personnel follow biosafety procedures prepared for special hazards in the laboratory
- The laboratory director should ensure that laboratory support personnel receive appropriate training on the potential hazards associated with their work and the necessary precautions to prevent exposure.
- Restrict access to the laboratory. In general, persons who are at increased risk of acquiring infection should not be allowed in the laboratory
- All persons entering the facility are advised of the potential hazards, are instructed on the appropriate safeguards, and read and follow instructions on practices and procedures.

- Personal health status may affect an individual's susceptibility to infection and ability to receive available immunizations or prophylactic interventions.
- Post a sign incorporating the universal biohazard symbol at the entrance to the laboratory when infectious materials are present. Posted information includes: the laboratory's Biosafety Level, the supervisor's or other responsible personnel's name and telephone number, PPE requirements, general occupational health requirements (e.g., immunizations, respiratory protection), and required procedures for entering and exiting the laboratory. Agent information is posted in accordance with the institutional policy.
- Long hair is restrained so that it cannot contact hands, specimens, containers, or equipment.
- Wear appropriate PPE to protect yourself from exposure to hazardous materials and PPE selection should be based on an appropriate risk assessment
- PPE are removed in a manner that minimizes personal contamination and transfer of infectious materials outside of the areas where infectious materials and/or animals are housed or manipulated.
- Persons wash their hands after working with potentially hazardous materials and before leaving the laboratory.
- Eating, drinking, smoking, handling contact lenses, applying cosmetics, and storing food for human consumption are not permitted in laboratory areas. Food is stored outside the laboratory area.
- Mouth pipetting is prohibited. Mechanical pipetting devices are used.
- Policies for the safe handling of sharps, such as needles, scalpels, pipettes, and broken glassware are developed, implemented, and followed
- Perform all procedures to minimize the creation of splashes and/or aerosols.
- Decontaminate work surfaces after completion of work and after any spill or splash of potentially infectious material with appropriate disinfectant.
- Decontaminate laboratory equipment's according to local regulations before being sent for repair.

- Spills involving infectious materials are contained, decontaminated, and cleaned up by staff who are properly trained and equipped to work with infectious material. A spill procedure is developed and posted within the laboratory.
- Report all spills and accidents that result in overt exposure to infectious materials to the laboratory director immediately
- Decontaminate all cultures, stocks, and other potentially infectious materials before disposal using an effective method,
- Laboratory personnel are provided medical surveillance, as appropriate, and offered available immunizations for agents handled or potentially present in the laboratory

### **5.2.2.3 Safety Equipment**

- Respect the use of laboratory coats, gloves, masks and face shields as described in the general practices section.
- Wear protective laboratory coats, gowns, or uniforms designated for laboratory while working with hazardous materials and removed before leaving for non-laboratory areas
- Use Eye protection and face protection (e.g., safety glasses, goggles, mask, face shield or other splatter guard) for manipulations or activities that may result in splashes or sprays of infectious or other hazardous materials
- The risk assessment considers whether respiratory protection is needed for the work with hazardous materials. If needed, relevant staff are enrolled in a properly constituted respiratory protection program.
- Use pipetting aids devices.
- Use screw capped tubes and bottles.
- Avoid the use of glass transfer loops. Metallic loops are acceptable if correctly used. Plastic disposable loops are the best if available.
- If available use biosafety cabinets when there is increased risk of aerosol production or airborne infection, e.g. grinding, blending, shaking, mixing, sonic disruption or centrifugation of infectious material. If centrifuges are equipped with sealed safety caps, centrifugation can be done in the open laboratory.
- An eye wash station should be available.

- Provide an autoclave or other means to decontaminate infectious materials.
- Certification and recertification of equipment are required at regular intervals according to the manufacturer's instructions.

### **5.2.3 Biosafety Level 3**

Biosafety Level 3 (BSL-3) standard practices, safety equipment, and facility specification are applicable to laboratories in which work is performed using indigenous or exotic biological agents with a potential for respiratory transmission and those that may cause serious and potentially lethal infection. The primary routes of exposure to personnel working with these types of biological agents and toxins relate to accidental exposure via the percutaneous or mucosal routes and inhalation of potentially infectious aerosols. At BSL-3, more emphasis is placed on primary and secondary barriers to protect personnel, the surrounding community, and the environment from exposure to potentially infectious aerosols

BSL 3 is applied to hazardous microorganisms primarily transmitted by the inhalation route that cause serious and potentially lethal disease (e.g. *Mycobacterium tuberculosis*,, *Coxiella burnetii*, The following sections describe the recommended standard practices, safety equipment, and facility specifications for BSL-3.

#### **5.2.3.1 Laboratory Facility Design and Facilities**

Separate the laboratory from areas that are open to unrestricted traffic flow within the building. Additional separation may be achieved by placing the laboratory at the blind end of a corridor, or constructing a partition with access through an anteroom (e.g., a double-door entry or basic laboratory Biosafety Level 2), describing a specific area designed to maintain the pressure differential between the laboratory and its adjacent space.

- The anteroom should have facilities for separating clean and dirty clothing.
- Anteroom doors may be self-closing and interlocking so that only one door is open at a time. A break-through panel may be provided for emergency exit use.
- Surfaces of walls, floors and ceilings should be water resistant and easy to clean.
- Openings through these surfaces (e.g. for service pipes) should be sealed to facilitate decontamination of the room(s).
- The laboratory room must be sealable for decontamination. Air-ducting systems must be constructed to permit gaseous decontamination.
- Windows must be closed, sealed and break-resistant.



- A hand-washing station with hands-free controls should be provided near each exit door.
- There must be a controlled ventilation system that maintains a directional airflow into the laboratory room. A visual monitoring device with or without alarm(s) should be installed so that staff can at all times ensure that proper directional airflow into the laboratory room is maintained.
- The building ventilation system must be so constructed that air from the containment laboratory – Biosafety Level 3 – is not recirculated to other areas within the building.
- Air may be high-efficiency particulate air (HEPA) filtered, reconditioned and recirculated within that laboratory.
- When exhaust air from the laboratory (other than from biological safety cabinets) is discharged to the outside of the building, it must be dispersed away from occupied buildings and air intakes. Depending on the agents in use, this air may be discharged through HEPA filters.
- A heating, ventilation and air-conditioning (HVAC) control system may be installed to prevent sustained positive pressurization of the laboratory. Consideration should be given to the installation of audible or clearly visible alarms to notify personnel of HVAC system failure.
- All HEPA filters must be installed in a manner that permits gaseous decontamination and testing.
- Biological safety cabinets should be placed away from walking areas and out of crosscurrents from doors and ventilation systems.
- The exhaust air from Class I or Class II biological safety cabinets which will have been passed through HEPA filters must be discharged in such a way as to avoid interference with the air balance of the cabinet or the building exhaust system.
- An autoclave for the decontamination of contaminated waste material should be available in the containment laboratory. If infectious waste has to be removed from the containment laboratory for decontamination and disposal, it must be transported in sealed, unbreakable and leak proof containers according to national or international regulations, as appropriate.
- Backflow precaution devices must be fitted to the water supply. Vacuum lines should be protected with liquid disinfectant traps and HEPA filters or an equivalent.

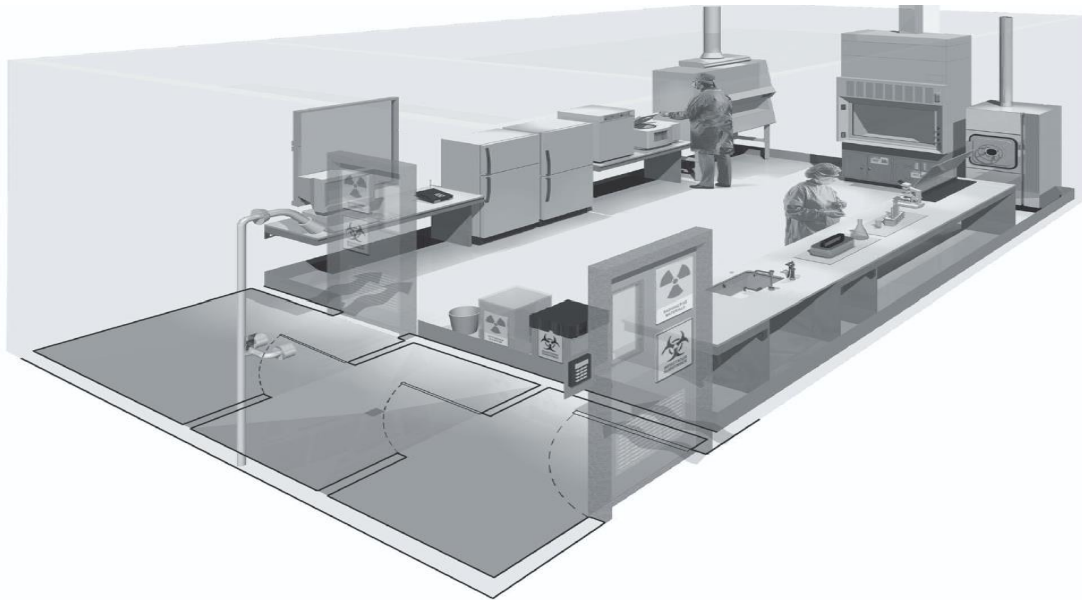

Figure 4: A typical design of biosafety level 3 laboratory (WHO 2004)

- Alternative vacuum pumps should also be properly protected with traps and filters. The containment laboratory – Biosafety Level 3 – facility design and operational procedures should be documented.

#### 5.2.3.2 Safety Equipment

- Laboratory workers wear protective clothing with a solid-front, such as tie-back or wrap-around gowns, scrub suits, or coveralls.
- Based on work being performed, additional PPE may be required.
  - Eye protection and face protection (e.g., safety glasses, goggles, mask, face shield or other splash guard) are used for manipulations or activities that may result in splashes or sprays of infectious or other hazardous materials.
  - Two pairs of gloves are worn when appropriate.
  - Respiratory protection is considered and staff wearing respiratory perform fit test
  - Shoe covers are considered.
- Consideration should be given to equipment such as centrifuges which will need additional containment accessories, for example, safety buckets or containment rotors.
- Use protective laboratory wrap-around gowns.
- Use gloves when handling infectious material, infected animals or contaminated equipment.

- Use Class I or Class II biological safety cabinet. When conduct manipulations of infectious materials in a
- When a procedure cannot be conducted in a safety cabinet, use appropriate personal protective equipment such as respirators and face shields and physical containment devices such as centrifuge safety cups.

### **5.2.3.3 Laboratory Practice and Procedures**

- Follow strictly the laboratory practices listed for Biosafety Level 2 with some additional, special safety practices which apply to agents manipulated at Biosafety Level 3.
- The laboratory director is responsible for ensuring that, before working with organisms at Biosafety Level 3, all personnel demonstrate proficiency in standard microbiological practices and techniques and in operations specific to the laboratory facility. This might include a specific training program provided by the laboratory director or other competent scientist proficient in safe microbiological practices and techniques.
- Conduct all manipulations of infected materials in biological safety cabinets.
- Do not conduct any work with open vessels on the open bench.
- Wear protective laboratory wrap-around gowns. Do not wear protective clothing outside the laboratory and decontaminate them before being laundered.
- Wear gloves when handling infectious material, infected animals or contaminated equipment.
- Change gloves frequently and do not reuse disposable gloves.
- Conduct all manipulations of infectious materials in a Class I or Class II biological safety cabinet.
- Spills of infectious material should be decontaminated, contained and cleaned up by appropriate professional staff or by others who are properly trained to work with concentrated infectious material.
- Develop spill procedures and post them.
- Decontaminate all contaminated materials such as gloves, lab coats, etc. before disposal or reuse.
- The laboratory personnel must have specific training in handling these pathogens and should be supervised by competent scientists.
- The guidelines for Biosafety Level 3 are additions to those for basic laboratories, therefore, Biosafety Levels 1 and 2 must be applied before those specific for the containment laboratory – Biosafety Level

3

#### **5.2.3.4 Surveillance**

- Medical examination of all laboratory personnel who work in containment laboratory Biosafety Level 3 should be mandatory. This should include recording of a detailed medical history and an occupationally-oriented physical examination.
- Immediately report accidental spills that result in overt or potential exposures to infectious materials to the laboratory director. Appropriate medical evaluation, surveillance and treatment should be provided, and written records should be maintained.

#### **5.2.4 Biosafety Level 4 (Maximum containment)**

Biosafety Level 4 (BSL-4) standard practices, safety equipment, and facility specification are applicable primarily for laboratories working with dangerous and exotic biological agents that pose a high individual risk of life-threatening disease that may be transmitted via the aerosol route and for which there is no available vaccine or therapy. Marburg virus and Congo-Crimean hemorrhagic fever virus are examples of the biological agents that meet these criteria. Agents with a close or identical antigenic relationship to agents requiring BSL-4 containment must be handled at this level until sufficient data are obtained either to confirm continued work at this level or to re-designate the level

The routes of exposure to personnel working with these types of biological agents relate to accidental exposure via the percutaneous and mucous membrane routes and inhalation of potentially infectious aerosols. The laboratory worker's complete isolation from aerosolized infectious materials is accomplished primarily by working in a Class III BSC or in a Class II BSC with a full-body, air-supplied positive-pressure personnel suit

The recommended standard practices, safety equipment, and facility specifications for BSL-4 are described below.

##### **5.2.4.1 Laboratory Facility Design and Facilities**

The features of a containment laboratory Biosafety Level 3 all apply to the Level 4 Biosafety laboratory with the addition of the following:

- Class III Biosafety Cabinet or cabinet room where passage through a minimum of two doors is required to enter into it; or a Suit Laboratory with different design from the Class III Biosafety cabinet.
- A personnel shower with inner and outer changing rooms is necessary.
- Supplies and materials that are not brought into the cabinet room through the changing area are

introduced through a double-door autoclave or fumigation chamber. Once the outer door is securely closed, staff inside the laboratory can open the inner door to retrieve the materials.

- The doors of the autoclave or fumigation chamber are interlocked in such a way that the outer door cannot open unless the autoclave has been operated through a sterilization cycle or the fumigation chamber has been decontaminated.

#### **5.2.4.2 Controlled Access**

- The maximum containment laboratory – Biosafety Level 4 – must be located in a separate building or in a clearly delineated zone within a secure building.
- Entry and exit of personnel and supplies must be through an airlock or pass-through system.
- On entering, personnel must put on a complete change of clothing; before leaving, they should shower before putting on their street clothing.

#### **5.2.4.3 Controlled Air System**

- Negative pressure must be maintained in the facility.
- Both supply and exhaust air must be HEPA filtered.
- The supply air to the Class III biological safety cabinet(s) may be drawn from within the room through a HEPA filter mounted on the cabinet or supplied directly through the supply air system.
- Exhaust air from the Class III biological safety cabinet must pass through two HEPA filters prior to release outdoors. The cabinet must be operated at negative pressure to the surrounding laboratory at all times.
- A dedicated non-recirculating ventilating system for the cabinet laboratory is required.
- All HEPA filters need to be tested and certified annually. The HEPA filter housings are designed to allow for in situ decontamination of the filter prior to removal.
- Alternatively, the filter can be removed in a sealed, gas-tight primary container for subsequent decontamination and/or destruction by incineration.

#### **5.2.4.4 Decontamination of Effluents**

- Decontaminate all effluents from the decontamination chamber, decontamination shower, or Class III biological safety cabinet before final discharge. Heat treatment is the preferred method.
- Correct effluents to a neutral pH prior to discharge.
- Water from the personnel shower and toilet may be discharged directly to the sanitary sewer without treatment.

#### **5.2.4.5 Sterilization of Waste and Other Materials**

- Provide a double-door, pass-through autoclave in the laboratory area.
- Provide other methods of decontamination for equipment and items that cannot withstand steam sterilization.

#### **5.2.4.6 Additional Design Requirements**

- Provide airlock entry ports for specimens, materials and animals.
- Provide emergency power and dedicated power supply line(s).
- Install containment drain(s).
- Because of the great complexity of the work in a Biosafety Level 4 laboratory, develop a separate detailed work manual and test it in training exercises.
- In addition, devise an emergency program. In the preparation of this program, establish active cooperation with national and local health authorities. Involve other emergency services, e.g., fire, police and designated receiving hospitals.

#### **5.2.4.7 Laboratory Practice and Technique**

- There should always be two persons working in the laboratory and no individual should work alone.
- Change clothing completely including shoes prior to entering and upon exiting the laboratory.
- Train personnel in emergency evacuation procedures in the event of injury to personnel or illness
- Provide a method of communication for routine and emergency contacts between personnel working within the maximum containment – Biosafety Level 4 – and support personnel outside the laboratory.

### **5.2.5 Laboratory Animal Biosafety Levels**

Those who use animals for experimental and diagnostic purposes have a moral obligation to take every care to avoid causing them unnecessary pain or suffering. Thus, the following key points should be considered:

- Provide the animals with comfortable, hygienic housing and adequate wholesome food and water.
- At the end of the experiment, deal with them in a human manner.
- For security reasons, the animal house should be an independent, detached unit. If it adjoins a laboratory, the design should provide for its isolation from the public parts of the laboratory should such need arise, and for its decontamination and disinfestations.
- Animal facilities, like laboratories, may be designated according to a risk assessment and the risk

group of the microorganisms under investigation, as Animal Facility Biosafety Level (ABSL) 1, 2, 3 or 4. In general, the biosafety level recommended for working with an infectious agent in vivo is comparable to that in vitro.

#### **5.2.5.1 Animal Facility Biosafety Level 1**

- Is required for animals inoculated with agents not known to cause disease in healthy adults (Risk group 1).
- Follow standard microbiological practices.
- Follow standard animal care and management practices including appropriate medical surveillance programs.
- Institute an appropriate medical surveillance program for the staff.
- Prepare and adopt a safety or operations manual.

#### **5.2.5.2 Animal Facility Biosafety Level 2**

- Is required for animals inoculated with infectious agents included in Risk group 2.
- In addition to all requirements of ABSL-1 practice, post biohazard warning signs on doors and other appropriate places.
- Limit access.
- Use personal protective equipment (PPE) such as laboratory coats, gloves and face protection as needed.
- Always collect sharps in puncture-proof or puncture-resistant containers fitted with covers and treat as infectious.
- Use Class I or Class II BSCs or isolator cages with dedicated air supplies and HEPA- filtered exhaust air for manipulations that cause splashes or aerosols of infectious agents.
- Decontaminate hazardous waste and cages before washing.
- An autoclave must be available on site or in appropriate proximity to the animal facility.
- If mechanical ventilation is provided, the airflow must be inwards. Exhaust air is discharged to the outside and should not be recirculated to any part of the building.
- Windows, if present, must be secure, resistant to breakage and, if able to be opened, must be fitted with arthropod-proof screens.
- Do not admit any animals other than those for experimental use.
- After use, decontaminate work surfaces with effective disinfectants.

- Put in place an arthropod and rodent control program.
- Remove animal bedding materials in a manner that minimizes the generation of aerosols and dust.
- Decontaminate all waste materials and bedding before disposal.
- Transport material for autoclaving or incineration safely in closed containers.
- Decontaminate animal cages after use.
- Incinerate animal carcasses.
- Provide hand-washing facilities. Staff must wash their hands before leaving the animal facility.
- Treat all injuries, however minor, appropriately and report and record them.
- Provide all personnel with appropriate training.
- Prepare a manual defining any special waste disposal and decontamination methods and/or medical surveillance policies.

### **5.2.5.3 Animal Facility Biosafety Level 3**

- Is suitable for animals inoculated with agents with potential for aerosol transmission (Risk Group 3) and where disease may have serious or lethal consequences.
- In addition to all requirements for ABSL-1 and 2 practices, strictly control lab access.
- Use PPEs such as laboratory coats and gloves. Use respiratory protection equipment as needed.
- Use Class I or Class II BSCs or other physical containment devices for all manipulations of infectious agents.
- There must be mechanical ventilation to ensure a continuous airflow through all the rooms. Exhaust air must pass through HEPA filters before being discharged to the atmosphere without recirculation. The system must be designed to prevent accidental reverse flow and positive pressurization in any part of the animal house.
- Separate the facility from other laboratory and animal house areas by a room with a double-door entrance forming an anteroom.
- Provide showers in the anteroom.
- Provide hand-washing facilities in the anteroom.
- An autoclave must be available at a location convenient for the animal house where the biohazard is contained.
- Autoclave infectious waste before it is moved to other areas of the facility.
- Decontaminate all waste.



- Decontaminate laboratory clothes before washing.
- An incinerator should be readily available on site or alternative arrangements should be made with the authorities concerned.
- Keep animals infected with Risk Group 3 microorganisms in cages in isolators or rooms with ventilation exhausts placed behind the cages.
- Bedding should be as dust-free as possible.
- Windows must be closed and sealed, and resistant to breakage.
- Immunization of staff, as appropriate, should be offered.

#### **5.2.5.4 Animal Facility Biosafety Level 4**

- In ABSL-4, work in this facility will normally be linked with that in the maximum containment laboratory, Biosafety Level 4, and national and local rules and regulations must be harmonized to apply to both. If work is to be done in a suit laboratory, additional practices and procedures must be used over and above those described here.
- All the requirements for animal facilities – Biosafety Levels 1, 2 and 3 – must be met.
- Strictly control access allowing only staff designated by the director of the establishment to enter.
- Apply the two-person rule. Individuals must not work alone.
- Give personnel the highest possible level of training as microbiologists and familiarize them with the hazards involved in their work and with the necessary precautions.
- Maintain the criteria for containment applied for maximum containment laboratories, Biosafety Level 4, for housing areas for animals infected with Risk Group 4 agents.
- The facility must be entered by an air-locked anteroom, the clean side of which must be separated from the restricted side by changing and showering facilities.
- Remove street clothing when entering and put on special protective clothing. After work remove the protective clothing for autoclaving and shower before leaving.
- Ventilate the facility by a HEPA-filtered exhaust system designed to ensure a negative pressure (inward directional airflow).
- The ventilation system must be designed to prevent reverse flow and positive pressurization.
- Provide a double-ended autoclave with the clean end in a room outside the containment rooms for exchange of materials.
- Provide a pass-through airlock with the clean end in a room outside the containment rooms for

exchange of non-autoclavable materials.

- Perform all manipulations with animals infected with Risk Group 4 agents under maximum containment – Biosafety Level 4 – conditions.
- House all animals in isolators.
- Autoclave all animal bedding and waste before removal from the facility.
- Perform medical supervision of staff.

### **5.3 Classification of Microorganism Risk Groups**

Different Laboratory Biosafety Levels 1-4 are designated for working with agents from the various risk groups. The different risk groups, however, do not necessarily always belong to the respective Biosafety Levels. The assignment of an agent to a biosafety level for laboratory work must be based on a risk assessment. Such an assessment will take the risk group as well as other factors into consideration in establishing the appropriate biosafety level.

The biosafety level assigned for the specific work to be done is driven by professional judgment based on a risk assessment rather than by automatic assignment of a laboratory biosafety level according to the particular risk group designation of the pathogenic agent to be used.

The assignment of a biosafety level takes into consideration the organism (pathogenic agent) used, the facilities available, and the equipment practices and procedures required to conduct work safely in the laboratory.

Depending on their relative hazards, infective microorganisms have been classified by the WHO into different risk groups, designated as Risk Groups 1, 2, 3 and 4. Classification of organisms according to risk group has traditionally been used to categorize the relative hazards of infective organisms. The factors used to determine which risk group an organism falls into is based upon the particular characteristics of the organism, such as

- Pathogenicity
- Infectious dose
- Mode of transmission
- Host range
- Availability of effective preventive measures

- Availability of effective treatment.

Four levels of pathogenic risk group classifications are to be used for laboratory work.

### **5.3.1 Risk Group 1**

- Risk group 1 is no or low individual and community risk
- A microorganism that is unlikely to cause human or animal disease.

### **5.3.2 Risk Group 2**

- Risk group 2 is moderate individual risk, low community risk.
- A pathogen that can cause human or animal disease but is unlikely to be a serious hazard to laboratory workers, the community, livestock or the environment. Laboratory exposures may cause serious infection, but effective treatment and preventive measures are available and the risk of spread of infection is limited.

### **5.3.3 Risk Group 3**

- Risk group 3 is high individual risk, low community risk.
- A pathogen that usually causes serious human or animal disease but does not ordinarily spread from one infected individual to another. Effective treatment and preventive measures are available.

### **5.3.4 Risk Group 4**

- Risk Group 4 is high individual and community risk.
- A pathogen that usually causes serious human or animal disease and that can be readily transmitted from one individual to another, directly or indirectly. Effective treatment and preventive measures are usually not available.

## Chapter 6: Occupational Health and Safety

It is defined as the science of anticipation, recognition, evaluation and control of hazards arising in or from work place that could impair the health and wellbeing of workers; taking into account the possible impact on surrounding communities & the general environment

The basic objectives of a good occupational health and safety program are:

- To promote health and protect employee's against health hazards in their work environment
- To match the work environment with the individual, and not the individual to the work environment.
- To ensure fitness to work medical assessments ascertain the physical capability of the employee to perform the duties assigned.
- To implement a health surveillance program that ensures periodic evaluation of medical status with an emphasis on prevention of exposure to occupational hazards and early detection of occupational exposures.
- To ensure occupational risk assessment is carried out for the workplace, occupational hazards identified, and preventive measures put in place to minimize exposure to staff.
- To implement an exposure/accident management program that ensures adequate, return to work procedures, exposure control plans, and emergency procedures.
- To implement occupational health and safety program.
- To implement periodic monitoring and evaluation of the occupational health program.

Laboratory workers are exposed to various occupational hazards resulting from interaction with patients and biological samples at their workplace. To minimize risk of exposure to these hazards it is important to develop an occupational health program. It is the responsibility of the organization to ensure that an operational program is in place. A sound occupational health program should address staff induction, training, fitness to work medical tests, health surveillance program, exposure/accident management plans, and incident reporting, investigation and mitigation plans.

### 6.1 Staff Induction

#### 6.1.1 Staff Induction

Induction is the process through which employees adjust or familiarize themselves with their new jobs and working environment. As part of this, "orientation" can be used for a specific event that new starters attend, and "socialization" can be used to describe the way in which new employees build working relationships within their new teams.

An induction is given to all new staff and staff transferred to a new job or position. It should be given within a short period of time and during initial employment or assignment to a new job. Induction should cover an introduction to the workplace and facility; an introduction to co-workers; an explanation of reporting structure; laboratory safety guidelines; and a risk assessment of the workplace, identifying all hazards. The length and nature of the induction depends on the job role, the new employee's background, and the size and nature of the organization. A standard induction course is unlikely to achieve its aims, so it should be adapted as appropriate for all new starters. The training also includes specific operational procedures and manuals.

## **6.2 Occupational Health and Safety Training**

This is continuous training given to staff to create awareness of occupational health hazards in the workplace. The training helps the employee to identify such hazards, understand control measures in place to minimize exposure to hazards, and know the exposure management plans in place in case of exposure. Occupational health and safety training should be conducted at least annually and it includes:

- Potential risks to the laboratory workers' health
- Blood borne and other body fluids pathogens
- Precautions to be taken to minimize aerosol formation and prevent exposure, and hygiene requirements,
- Universal precautions, warning and use of personal protective equipment (PPE) and work practice and handling of potentially infectious materials
- Prevention of incidents/accidents and steps to be taken by workers in the event of an incidents/accidents occurring due to (biological, chemical, electrical, fire hazards etc.)
- Laboratory design, organization of workflow including airflow conditions
- Equipment safety
- Good laboratory practice
- Hazard control plan
- Waste handling in the laboratory

## **6.3 Pre-placement Medical Examination and Medical Surveillance program**

### **6.3.1 Pre-Placement Medical Examination**

The primary purpose of pre-placement medical examinations is to make sure that an individual is fit to perform the tasks involved effectively and without risk to their own or others' health and safety, which means

fitness to work medical tests. The medical evaluation of the employee should be carried out by the physician and should be done before the employee takes up the new position.

### **6.3.2 Medical Surveillance Program**

This is a continuous medical evaluation program for all workers within their work environment. The evaluation depends on the occupational health risk assessment and occupational hazards identified. For laboratory workers, this evaluation should be done annually or after an incident that could result in exposure or at the onset of symptoms of any work-related illness.

## **6.4 Exposure/Accident Management Plans**

Occupational exposure is an occupational hazard present in the workplace. There are different types of occupational exposures, such as biological, electrical, chemical, radiation, fire, mechanical, physical, ergonomical, and psychosocial (work-related pressure) hazards. The common occupational exposure in health laboratories is biological exposure. A biological exposure results from exposure to biological hazards and can result from percutaneous injury (needle-stick or other sharp injury), mucocutaneous splashing (splashing of blood or other body fluids into the eyes, nose, or mouth), specimen contact with intact or non-intact skin, or respiratory exposure by inhalation. Occupational accidents usually occur at the workplace or while carrying out workplace activities. There are several factors involved in occupational accidents, such as failure to follow procedures, poor knowledge and skill, carelessness, unsafe handling of hazardous materials, poor safety practices, improper use of PPE, etc.

So that implementing exposure and accident management plans and establishing clear procedures for exposure and accident investigation, mitigation, and reporting assists laboratories in avoiding significant loss due to exposures and accidents

### **6.4.1 Occupational Exposure/Accident Management Plans**

These are procedures put in place by the facility to ensure that pain and suffering resulting from all occupations exposures and accidents are minimized. These should include the following:

- Training
- Vaccination: Health care workers should be vaccinated against vaccine preventable diseases which include HBV, yellow fever vaccine etc

- Personal protective equipment: Laboratory staff should be provided with PPE that adequately protect them from the risks they are exposed to. Proper use of PPE and training is important.
- Post exposure prophylaxis (PEP): There should be a documented PEP plan in place at every health facility based on risk assessment. Proper PEP management includes incident and accident reporting, management and monitoring (annex 4).
- First aid and medical surveillance
- Regular safety inspection, preventive and corrective action

#### **6.4.2 Incident Investigation, Mitigation and Reporting Plans**

Reporting occupational incidents and accidents helps facilities to keep track of all occupational incidents and accidents at the facility. Proper investigation will ensure the actual cause of the incident and/or accident is identified so that adequate plans will be put in place to prevent reoccurrence. Successful implementation of these plans requires an effective biosafety committee and/or infection prevention and control committee (IPCC) with support from the health facility management team.

#### **6.4.3 Incident/Accident Investigation**

For the facility to effectively implement incident/accident investigation, the following should be required:

- Incident/accident investigation procedure
- Incident/accident investigation tool
- Incident/accident investigation report format

#### **6.4.4 Incident/Accident Mitigation Plans**

The facility should prepare an incident/accident mitigation plans as per the root causes, the following materials are required for preparation of mitigation plan:

- Incident/accident investigation reports
- Emergency preparedness and response plans addressing identified potential hazards
- Mitigation, monitoring and evaluation tool

#### **6.4.5 Incident/Accident Reporting**

The incident/accident reporting should include the description of incident or accident occurred, investigation report, action taken and follow up plan.

## Chapter 7: Laboratory Safety Equipment

Safety equipment is a primary barrier or primary containment, is defined as physical containment measure(s) placed directly at the level of the hazard. Safety equipment such as biological safety cabinets (BSCs), enclosed containers, and other biosafety controls are designed to protect personnel, the surrounding community, and the environment from possible exposure to hazardous biological agents and toxins. Different types of safety equipment are used by workers depending upon the nature of risk involved in the work. Facility management is responsible to provide appropriate safety equipment for employees and the employees should train on how to use the safety equipment

### 7.1 Personal Protective Equipment

Personal protective equipment helps protect the user's body from exposure to or contact with infectious agents and injury from a variety of sources (e.g., physical, electrical, heat, noise, chemical) or potential exposure to biological hazards and airborne particulate matter. These include gloves, face masks, protective eyewear, face shields, footwear, respiratory protection, and protective clothing (e.g., reusable or disposable gown, jacket, and lab coat, etc.) which can decrease the risk of exposure to hazardous substances due to splashes, accidental or aerosol inoculation, and to prevent illnesses and injuries while working in a potentially hazardous environment. Facility Management is responsible for providing appropriate personal protective equipment (i.e., gloves, lab coats, eye protection, etc.) in usable condition.

#### 7.1.1 Laboratory Coats, Gowns, and Aprons

- Fully button up laboratory coats.
- Long-sleeved, back-opening gowns give better protection than laboratory coats and are preferred in laboratories and when working at the biological safety cabinet.
- Wear aprons over laboratory coats or gowns where necessary to give further protection against spillage of chemicals or biological materials such as blood or culture fluids.
- Laundry services should be provided at/near the facility.
- Do not wear laboratory coats or gowns outside the laboratory areas.

#### 7.1.2 Eye Protection

- Safety glasses, safety goggles, face shields (visors) or other protective devices must be worn whenever it is necessary to protect the eyes and face from splashes, impacting objects and artificial



ultraviolet radiation.

- Eye protection can be used but must be regularly cleaned. If splashed, it must be decontaminated with an appropriate disinfectant
- Personal prescription glasses (spectacles) must not be used as form of eye protection as they do not cover enough of the face around the eyes, particularly around the side of the head. Specialized prescription safety glasses must be purchased for personnel with such needs. Some goggles are available that have recesses that enable the user to wear glasses underneath them.

### **7.1.3 Gloves**

- Appropriate disposable gloves must be worn for all procedures that may involve planned or inadvertent contact with blood, body fluids and other potentially infectious materials. They must not be disinfected or reused as exposure to disinfectants and prolonged wear will reduce the integrity of the glove and decrease protection to the user. Gloves should always be inspected before use to check they are intact.
- Wear special gloves when there is a potential exposure to sharp instruments, such gloves protect against slicing motion but do not protect against puncture injury. Do not wear gloves outside the laboratory areas.
- Use utility or heavy-duty household gloves for cleaning instruments, equipment and other items and when handling and disposing of contaminated waste as well as when cleaning contaminated surfaces.

### **7.1.4 Footwear**

- Footwear must wear in the laboratory and must be of a design that minimizes slips and trips and can reduce the likelihood of injury from falling objects and exposure to biological agents.
- It should cover the top of the foot and should be well- fitting and comfortable to allow personnel to perform their tasks without fatigue or distraction.

### **7.1.5 Respiratory Protection**

A respirator/ respiratory protection is a personal protective device that is worn on the face, covers at least the nose and mouth, and is used to reduce the wearer's risk of inhaling hazardous airborne particles (including dust particles and infectious agents), gases, or vapors.

- The choice of respirator will depend on the type of hazard.
- Surgical type masks are designed solely for patient protection and do not provide respiratory

protection to workers.

#### **7.1.5.1 Filtering Facepiece Respirator**

A filtering facepiece respirator (FFR) is a device that is a disposable half-face-piece non-powered air-purifying particulate respirator intended for use to cover the nose and mouth of the wearer to help reduce exposure to pathogenic biological airborne particulates. The types of masks and their efficacy are described in this section.

- **An N95 respirator:** it is a respiratory protective device designed to achieve a very close facial fit and very efficient filtration of airborne particles. Note that the edges of the respirator are designed to form a seal around the nose and mouth. It is widely used and blocks at least 95% of very small (0.3 micron) particles. In addition to this, there are other types of masks such as N99, N100, and N95 with a capacity to filter at least 99% and 99.97% of airborne particles, respectively.
- **Filtering Facepiece Respirator (FFP):** it is the European Union standard. Classified as FFP1, FFP2 and FFP3, they filter at least 80%, 94% and 99% of airborne particles, respectively.
- **R95 Respirators:** they are oil resistant and block out 95% of all airborne particles. There are also R99 and R100 respirators that are oil-resistant and can filter out up to 99% and 100% of airborne particles, respectively.
- **P95 Respirators:** they are strongly resistant to oil. P95 respirator filters least 95% of airborne particles. There are also P99 and P100 respirators that are strongly oil-resistant and can filter out up to 99% and 100% of airborne particles, respectively.
- **Surgical masks:** they are defined as medical masks that are flat or pleated. A surgical mask is a loose-fitting, disposable device that creates a physical barrier between the mouth and nose of the wearer and potential contaminants in the immediate environment. Surgical masks may be effective in blocking splashes and large-particle droplets; they do not provide a reliable level of protection from aerosolized particles because of the loose fit between the surface of the mask and your face.

#### **7.1.5.2 Powered Air-Purifying Respirator (PAPR)**

A PAPR is an air-purifying respirator that uses a battery-operated fan to pull air through a HEPA filter. Filtered air flows across the inside of the face shield (prevents fogging) and vents either through a cuff at the neck or under the gown, offering more protection than N-95. Filters must be replaced according to the manufacturer's instructions.

### 7.1.5.3 Self-Contained Breathing Apparatus (SCBA)

A self-contained breathing apparatus sometimes referred to as a compressed air breathing apparatus or simply breathing apparatus, is a device worn to provide breathable air in an atmosphere that is immediately dangerous to life or health.

## 7.2 Biosafety Cabinets (BSC)

A biological safety cabinet (BSC) is a primary containment/ engineering control used to protect personnel against biohazardous or infectious agents and to help maintain quality control of the material being worked with as it filters both the inflow and exhaust air. The BSC is primarily designed to protect against exposure to particulates or aerosols. A portion of the air in most BSCs is recirculated back into the lab through its exhaust HEPA filter. There are three types of BSCs described below and see table 7. **Class I BSC**

The Class I BSC is Open-fronted cabinets with an inward airflow designed to protect the operator and the environment from infectious aerosols generated. Simple airflow design allows them to maintain performance in most laboratory situations. The Class I BSC is widely used because of its simple design. Room air is drawn in through the front opening below the transparent window. The air passes over the work surface and is discharged from the cabinet through a HEPA filter through the exhaust duct to the outside, ensuring that infectious organisms are not discharged into the room air (see Figure 5).

- It protects the personnel against the inhalation of infectious aerosols.
- Class I BSC can also be used for work with volatile toxic chemicals.

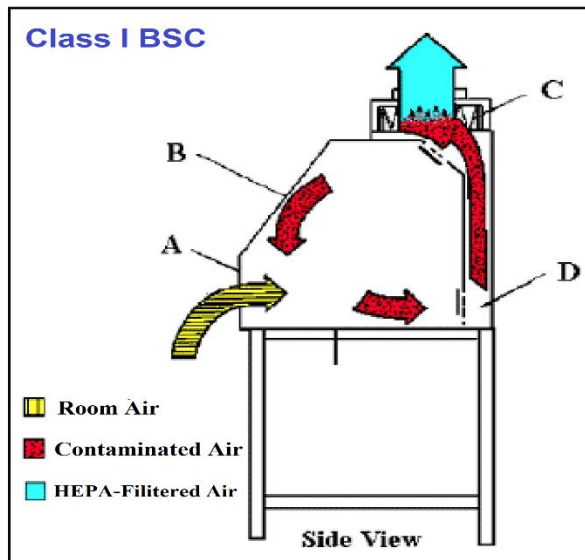

A: Front open; B: Sash; C: Exhaust HEPA; D: Supply HEPA filter

Figure 5: Type of class I BSC and its air flow direction

### 7.2.1.1 Class II BSC

The Class II BSC provides protection for personnel as well as the work surface and materials from contaminated room air. Several different Class II BSCs exist, each of which has slightly different airflow arrangements and/or mechanisms. One of the most commonly used BSCs in laboratory facilities is the Class II type A2. These open-fronted cabinets have a complex airflow pattern, which mixes inflow air with internally filtered down-flow air. This provides protection to work surface materials e.g. cell cultures in addition to users and the environment.

The complex airflow of Class II BSCs means their performance can easily be affected by factors such as cabinet positioning, room ventilation rates and pressure differences. For this reason, Class I BSCs may be a more sustainable choice because of their simpler design and the robustness of their protection to the operator when product protection is not a major consideration. In addition, the air balance can be also easily disturbed by doors nearby being constantly opened and closed, putting a lot of equipment in the cabinet, etc. Therefore, the cabinet must be properly installed (away from doors) and regularly serviced.

Air from the workspace is passed through an appropriate filter before discharge. This air can be recirculated to the room, discharged to the outside of the building through a thimble duct/canopy hood connection to a dedicated duct, or discharged through the building's heating, ventilation, and air conditioning exhaust system (Figure 6).

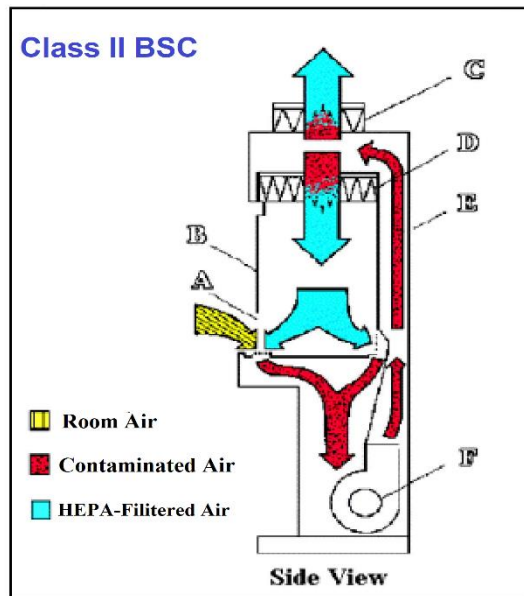

A: Front open; B: Sash; C: Exhaust HEPA; D: Supply HEPA filter; E: Exhaust plenum; F: Blower  
Figure 6: Type of class II BSC and its air flow direction

- There are five types of Class II BSCs: A1, A2, B1, B2 and C1 (Table 7)
  - Class II type A1 BSC an internal fan draws room air (supply air) into the cabinet through the front opening and into the front intake grill.
  - Class II type A2 BSC vented to the outside, B1 and B2 BSCs are the variations of the type A1.

Table 7: Comparison of biosafety cabinet characteristics

BSC Class	Face Velocity	Airflow Pattern	Application: Non-volatile Toxic Chemicals	Application: Volatile Toxic Chemicals
Class I	75	In at front through HEPA to the outside or into the room through HEPA.	Yes	When exhausted outdoors
Class II, A1	75	70% recirculated to the cabinet work area through HEPA; 30% balance can be exhausted through HEPA back into the room or to outside through a canopy unit	Yes (small amounts)	Yes (small amounts)
Class II, B1	100	30% recirculated, 70% exhausted. Exhaust cabinet air must pass through a dedicated, internal cabinet duct to the outside through a HEPA filter	Yes	Yes (small amounts)
Class I, B2	100	No recirculation; total exhaust to the outside through a HEPA filter	Yes	Yes (small amounts)
Class II, A2	100	Similar to II, A1, but has 100 lfm intake air velocity exhaust air can be ducted to the outside through a canopy unit	Yes	When exhausted outdoors (formally B3), (small amounts)
Class II, C1	100	30% recirculated, 70% exhausted. Exhaust cabinet air must pass through a dedicated, internal cabinet duct to the outside through a blower and HEPA filter	Yes	Yes (small amounts)
Class III	Not applicable	Supply air is HEPA-filtered. Exhaust air passes through two HEPA filters in series and is exhausted to the outside via a hard connection	Yes	Yes (small amounts)

**Note:** Installation requires a special duct to the outside, and may require an in-line charcoal filter, and/or a spark-proof (explosion-proof) motor and other electrical components in the cabinet. Discharge of a Class I or Class II, Type A2 cabinet into a room should not occur if volatile chemicals are used.

### 7.2.1.2 Class III BSC

The Class III BSC is a closed-fronted design that provides complete separation between the material being handled and the operator/environment. Access to the work-surface is by means of strong rubber gloves attached to ports in the cabinet (Figure 7). Class III cabinets are airtight and both supply and exhaust air are filtered, and high rates of air change are maintained within the cabinet. Airflow is maintained by a dedicated exhaust system outside the cabinet, which keeps the cabinet interior under negative pressure compared to the surrounding space. Additional features, such as pass boxes or dunk tanks, can be used to bring material into the cabinet, and/or to decontaminate it before bringing it out of the cabinet after use.

Class III BSC provides the highest level of personnel protection and is used for organisms with the highest risk of transmission. Access to the work surface is by means of heavy duty rubber gloves, which are attached to ports in the cabinet. The Class III cabinet may be connected to a double-door autoclave used to decontaminate all materials entering or exiting the cabinet and class III BSCs are suitable for work in Biosafety Level 3 and 4 laboratories.

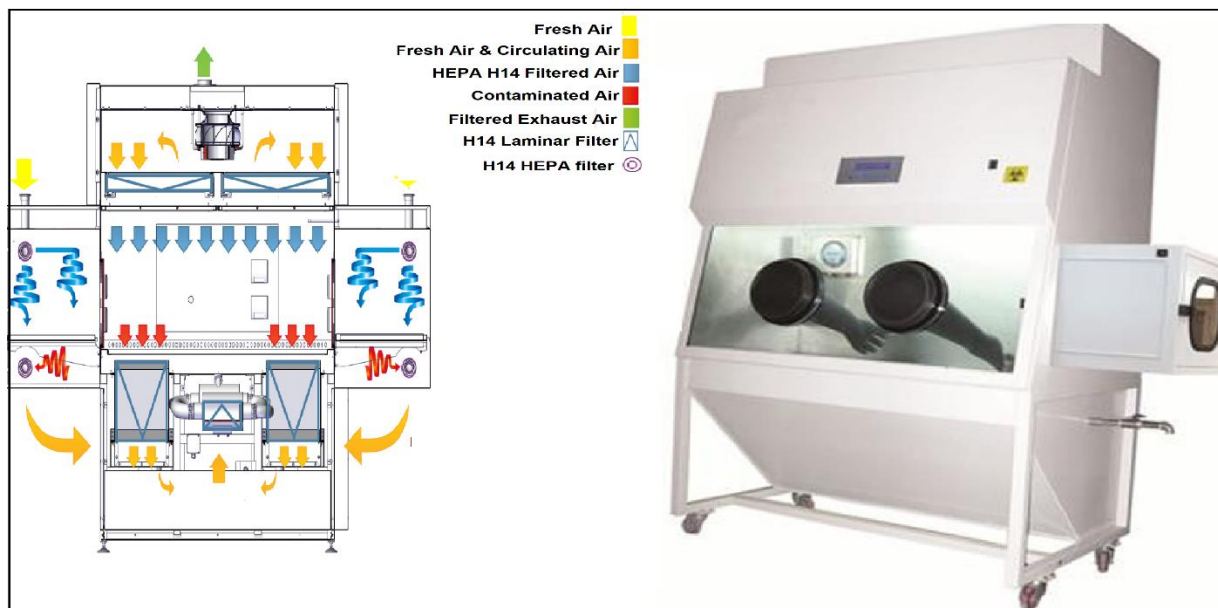

Figure 7: Type of class III BSC and its air flow direction

### 7.3 Isolators

The negative-pressure, flexible-film isolator is a self-contained primary containment device that provides a high degree of user protection against hazardous biological materials. Their flexibility and customized design means isolators can be fit-for-purpose. They are often used to house infected animals. Solid-wall isolator systems are also widely used, although they are more affected by pressure changes.

- The workspace is totally enclosed in a transparent envelope suspended from a framework.
- Access to the workspace may be through integrated sleeve-type gloves or an internal “half-suit”, both accessed externally.
- The isolator is maintained at an internal pressure lower than atmospheric pressure.
- Inlet air is passed through one filter and outlet air is passed through one or two filters, thus avoiding the need to duct exhaust air outside the building.
- Effective pressure monitors are required to ensure correct operation.

- Pass boxes, dunk tanks or rapid transfer ports can also be used for the introduction, removal and decontamination of work materials.

#### **7.4 Local Exhaust Ventilation**

For some operations, a ventilated workstation will be adequate to control any aerosols generated by Procedure. This can be constructed by connecting an open-fronted box to a HEPA-filter attached to a fan to provide an internal airflow. However, unless specifically designed for biological containment work, the performance may not be as effective as BSCs.

#### **7.5 Fume Hoods/ Cupboards**

A fume hood is a ventilated enclosure in which gases, vapors and fumes are captured and removed from the work area. An exhaust fan situated on the top of the laboratory building pulls air and airborne contaminants through connected ductwork and exhausts them to the atmosphere. Considerations should be given during the use of fume hood;

- Use fume cupboards only when dealing with chemicals that release noxious fumes.
- Do not use them for any microbiological work.
- Exhaust ducts must be a minimum of one meter above the highest part of the roof and should be fitted with a non-return valve.
- Check the air-flow system of the fume cabinets regularly, for example by using a burning stick of incense. If it shows any irregularities, close the unit and request for service

#### **7.6 Laminar Flow Hood**

A Laminar flow hood/cabinet is an enclosed workstation that is used to create a contamination-free work environment through filters to capture all the particles entering the cabinet. However, it does not provide protection to personnel or to the ambient environment.

- It is designed to protect the work from the environment and are most useful for the aseptic distribution of specific media and plate pouring.
- It provides product protection by ensuring product in the bench is exposed only to HEPA filtered air.
- The clean bench is recommended for work with non-hazardous materials where clean, particle free air quality is required.

## **7.7 Safety Considerations for Equipment Used for Laboratory Work**

Laboratory equipment can be hazardous if not used and maintained properly. Laboratory personnel must be trained prior to use the equipment. Laboratory personnel should review and follow instructions provided in the manufacturer's manuals and SOPs; should be located with the equipment or in a location that is easily accessible. Maintenance or repairs to any laboratory equipment should only be performed by a qualified individual. Safety devices on laboratory equipment must never be disabled or altered.

### **7.7.1 Biosafety Cabinets**

Select biosafety cabinets in accordance with the type of protection required; i.e. worker protection against infectious agents or volatile toxic chemicals, or product protection or a combination thereof.

- Install the cabinet properly away from doors so that the air balance in the cabinet will not be easily disturbed by doors nearby being constantly opened and closed.
- Do not put a lot of equipment in the cabinet.
- Limit movement of arms in and out of the cabinet. Put all materials necessary inside the cabinet before starting the manipulations.
- Keep materials away from the grills and towards the rear of the cabinet.
- Report any malfunction before using the cabinet and get the cabinet repaired by qualified technicians.
- Avoid open flames in the cabinet.
- Decontaminate spills of biohazardous materials and all materials that came in contact immediately with an appropriate disinfectant.
- Post a copy of the decontamination protocol.
- Decontaminate the interior surface of the cabinet and all materials inside after each use and at the end of each day.
- Decontaminate by fumigation before filter changes or before moving a BSC
- BSCs are equipped with airflow alarms for indicating the correct level of front door openings. Follow the manufacturer's instructions. Get the cabinet serviced and certified as per the manufacturer's recommendation and laboratory quality policies and procedures.



### 7.7.2 Pipettes and Pipettors

Mechanical pipetting devices shall be used for all work with chemical and biological agents. The use of mechanical pipetting devices does not completely eliminate all hazards associated with pipetting. The following shall be taken as precautionary measures:

- When using automatic pipettors, pipettes or tips, use ones that hold a larger volume than the volume needed to be pipette
- Perform pipetting of biological hazards in a BSC and pipetting of toxic materials in a fume hood
- Place used pipettes in disinfectant solution
- Disinfect pipettors or pipetting aids when contaminated and on a regular basis
- Use plastic Pasteur pipettes when possible
- Use pipettes plugged with cotton when working with potentially biological hazards
- Use mark-to-mark pipettes to avoid expelling the last drop
- Expel liquids slowly down the sides of a tube to avoid aerosol creation by splashing
- Pipetting by mouth of any material including distilled water is strictly prohibited
- Wear gloves when dismantling pipettes to clean or lubricate them.

### 7.7.3 Centrifuges

Centrifuge is a laboratory device that is used for the separation of fluids, gas or liquid, based on density and can create aerosols, and this must be considered with each use. The necessary precautions taken will depend upon what is being used. If hazardous materials such as carcinogens, highly toxic, or infectious agents will be placed in a centrifuge, then precautions must be taken to prevent the exposure of lab personnel to aerosols or liquids. Improper care of a centrifuge and its components can lead to exposure to hazardous substances, injuries, damaged equipment and lab space, and a loss of research, money, and time. Thus, laboratory personnel shall use centrifuge properly and do the following activities but not limited during the use of the equipment:

- Operate centrifuges according to the manufacturer's instructions.
- Place centrifuges at such a level that workers can see into the bowl to place rotors and buckets correctly.
- Use centrifuge tubes and specimen containers for use in centrifuges made of thick-walled glass or preferably of plastic; inspect them for defects before use.
- Securely cap tubes and specimen containers (screw-capped if possible) for centrifugation.

- Correctly balance buckets and rotors pairing them by weight with tubes in place.
- Follow the manufacturers' instructions for the amount of space that should be left between the level of the fluid and the rim of the centrifuge tube.
- Use sealable centrifuge buckets (safety cups) for microorganisms in Risk Groups 3 and 4.
- Decontaminate buckets, rotors and centrifuge bowls regularly.
- Remove broken tubes with gloved hands, using forceps, and put the pieces directly into a sharp's container for disposal.
- For use in micro-hematocrit centrifuges, seal them by heating as the use of clay is hazardous.

#### **7.7.4 Homogenizers, Vortexes, Blenders and Sonicators**

Homogenizer, vortexes, blenders, and sonicators are pieces of laboratory equipment used for laboratory activities. For instance, a vortex is a device used commonly in laboratories to mix small vials of liquid and a homogenizer used for the homogenization of various types of material. Laboratory personnel shall use Homogenizers, vortexes, blenders and sonicators properly and do the following activities but not limited during the use of these equipment

- Do not use domestic (kitchen) homogenizers in laboratories as they may leak or release aerosols. Laboratory blenders are safer.
- Use caps which are well-fitting and gaskets that are in good condition.
- Plastic Poly Tetra Fluoro-Ethylene (PTFE) vessels are recommended because glass may break, releasing infectious materials and possibly wounding the operator.
- Where possible, operate these machines under their plastic covers, in a biological safety cabinet. If no such cabinet is available, use transparent bench shields or wear a full-face shield.
- Minimize droplet formation, splashing and spillage while working with specimen materials.
- Hold glass tissue grinders in absorbent material in a gloved hand. Plastic (PTFE) grinders are safer.

#### **7.7.5 Autoclave**

Autoclave is a medical equipment that provides a physical method for disinfection and sterilization. It works with a combination of steam, pressure and time. Autoclaves operate at high temperature and pressure in order to kill microorganisms and spores and decontaminate certain biological waste and sterilize media, instruments and lab ware. Laboratory personnel shall be trained on how to use autoclaves and practice all safety requirements

### **7.7.6 Water Baths**

Water bath is a laboratory equipment that is used to incubate samples at a constant temperature over a long period of time. It is a preferred heat source for heating flammable chemicals instead of an open flame to prevent ignition. Laboratory personnel shall use water bath properly and do the following activities but not limited during the use of these equipment

- The continuity to ground in the plug to the water bath case shall be regularly verified to prevent electrical shock.
- Microbiological contamination in water baths shall be prevented by adding disinfectant (e.g. phenolic detergent).
- Water baths shall be unplugged prior to filling or emptying.

### **7.7.7 Microscopes**

A microscope is a piece of scientific equipment that lets us see very small things that our eyes otherwise couldn't see. The following shall be taken as precautionary measures applicable to microscopes:

- To reduce injuries related to frequent microscope use, workstations should be set up ergonomically with microscope work being alternated with other tasks where possible
- Ergonomically designed microscopes should be utilised.
- For electrical safety, cords, plugs and connections shall be regularly inspected for deterioration or corrosion.
- When using fluorescent microscopes, proper shielding should be in place during operation and alignment.
- A face shield and gloves should be worn when changing a fluorescent high-pressure mercury bulb.
- Stage, eyepieces, knobs and any other parts of the microscope which can become contaminated shall be disinfected after use (a 1:16 sporicidin solution is recommended).
- Radiation dosimeters as well as personal protective equipment should be worn by users of electron microscopes as necessary for work with the hazardous chemicals uses as fixatives or preparatory agents.

### **7.7.8 Laboratory Analyzers**

Laboratory analyzers are devices used to diagnose diseases, analyze certain analytes, count cells, and calculate the concentration of certain substances within samples of serum, plasma, urine, other body fluids

and environmental samples. Laboratory personnel shall be trained on how to use Laboratory analyzers and do the following activity during the use of Laboratory analyzers

- Assess the ways by which laboratory analyzers can give rise to environmental contamination and take measures to minimize this contamination
- Disinfect the shields and surrounding areas at least once daily.
- Discard carefully the contaminated wiping material used.
- Use a pipetting device to load samples into cups or trays and do not decant.
- Chemicals may be discharged directly into the municipal waste when the automated analyzer is attached.
- Clean and disinfect the laboratory analyzers according to manufacturers' instructions and the laboratory's quality policy and procedures.
- It is the responsibility of the laboratories to ensure that instruments are disinfected before any maintenance or repair is carried out.

#### **7.7.9 Use of Refrigerators and Freezers**

- Refrigerators, deep-freezers and solid carbon dioxide (dry ice) chests should be defrosted and cleaned periodically, and any ampoules, tubes, etc. that have broken during storage removed. Face protection and heavy duty rubber gloves should be worn during cleaning.
- After cleaning, the inner surfaces of the cabinet should be disinfected as per manufacturer's instructions.
- All containers stored in refrigerators should be clearly labeled with the scientific name of the contents, the date stored and the name of the individual who stored them. Unlabeled and obsolete materials should be autoclaved and discarded.
- An inventory must be maintained of the freezer's contents.
- Flammable solutions must not be stored in a refrigerator unless it is explosion-proof.
- Stand the refrigerators as per the manufacturer recommendation

#### **7.7.10 Equipment Decommissioning**

Decommissioning is removal of a laboratory equipment from service in a health facility after a decision to discontinue the medical device itself or the method when it reaches to the cycle of functional retirement. The two main pathways for decommissioning a medical device and determining its final disposition after

decontamination are permanent elimination (e. g. recycling, cannibalizing or incineration) and re-use (i.e. donated, sold, refurbished, reprocessed, traded-in or reassigned internally to another location). The steps in decommissioning medical devices depend on the option chosen:

First, risk and cost should be assessed to determine the best course of action in relation to the personnel and infrastructure available. The next stage is to ensure that the device is safe for handling and treatment or removal, by cleaning and decontaminating it, removing patient data. In a final step, the preceding stages and the end status of the device should be documented in a report for future reference. Key step to follow:

- For all equipment, the manufacturer’s instructions and safety notifications shall be reviewed to ensure proper dispose.
- All equipment shall be decontaminated prior to servicing, transporting or disposal
- Risk auditing, any risks related to decommissioning should be assessed. Consideration should be given to the health and safety of patients, the public, the environment and health care workers. A comprehensive plan should be outlined for the mitigation, transfer or monitoring of any risk.
- Appropriate people should be consulted, such as a qualified safety officers, facility manager and the bioengineers of manufacturer focal, to ensure safe removal of the device.
- For laboratory equipment containing hazardous material, emergency equipment must be functional, accessible and available. Equipment such as fire extinguishers, eye wash, emergency showers, ventilation and spill kits may be necessary.
- All decommissioning history document need to be archived; the administration of the health facility may require a “decommissioning document” in order to remove the device from the asset registry.

## Chapter 8: Laboratory Biosecurity

Laboratory biosecurity refers to a security measures designed to prevent the loss, theft, misuse, diversion or intentional release of biological agents and data being handled in the laboratory. Addressing laboratory biosecurity risks in many ways parallels and complements that of biosafety risk management. A development of a biosecurity strategy to manage the biosecurity risk should be in place by selecting and implementing biosecurity risk control measures. With objective evidence of the health institution's needs and regulatory framework.

There are many challenges associated with the implementation of biosecurity programs. For instance, many hazardous biological agents might only be used in very small quantities or may be capable of self-replicating, making them difficult to detect or reliably quantify. In some cases, the process of quantification may itself pose biosafety and biosecurity risks. Moreover, the interest in the use of these biological agents for such diagnostic, commercial, medical, and research applications has increased globally. For this reason, it is important to properly assess potential biosecurity risks and establish appropriate risk control measures that can reduce risks without hindering scientific processes and progress. Thus, it is advised to implement a risk assessment framework in order to properly assess potential biosecurity risks at facility level.

The following sections briefly describes risk assessment framework and the key elements of a laboratory biosecurity program, including its risk assessment framework.

### 8.1 Biosecurity Risk Assessment

A risk assessment focuses on proper asset identification, anticipated threat, vulnerability, and establish appropriate mitigation measures; that can reduce risks without hindering scientific processes and progress. These measures should comply with national standards and regulatory procedures and be proportionate to the assessed risks. Biosecurity risk assessment can often be combined with a biosafety risk assessment rather than being a stand-alone activity.

There are different types of biosecurity risk assessment models. Most models share common components such as asset identification, threat, vulnerability, and mitigation. The assessment and control measure plan should include input from senior professionals, scientific directors, biosafety officers, laboratory staff, bioengineers, administrators, information technology staff, law-enforcement agencies and security staff. The

entire risk assessment and risk management process may be divided into five main steps, each of which can be further subdivided. A guidance for these five steps is described below.

**Step 1:** Identify and Prioritize Biological Materials, Research-Related Information, and Technology

- Identify the form of the material, location, and quantities, including non-replicating materials (e.g., toxins)
- Evaluate the potential for misuse of these assets.
- Evaluate the consequences of misuse of these assets.

**Step 2:** Identify and Prioritize the Threat to Biological Materials, Research related Information, and technology

- Identify the types of “Insiders” who may pose a threat to the biologic materials, research-related information, and technology at the institution
- Identify the types of “Outsiders” (if any) who may pose a threat to the biologic materials, research-related information, and technology at the institution
- Evaluate and prioritize the motive, means, and opportunity of these various potential adversaries.

**Step 3:** Analyze the Risk of Specific Security Scenarios

- Develop a list of possible laboratory biosecurity scenarios or undesired events that could occur at the institution. Each scenario is a combination of an item, an adversary, and an action. Consider:
  - Access to the item within the laboratory
  - How the undesired event could occur
  - Protective measures in place to prevent occurrence; and
  - How the existing protection measures could be breached
- Evaluate the probability of each scenario materializing (i.e., the likelihood) and its associated consequences. Assumptions include:
  - Although a wide range of threats are possible, certain threats are more probable than others
  - All agents/assets are not equally attractive to an adversary; valid and credible threats, existing precautions, and the potential need for select enhanced precautions are considered.
- Prioritize or rank the scenarios by risk for review by management.

**Step 4:** Develop an Overall Risk Management Program

- Management commits to oversight, implementation, training, and maintenance of the laboratory biosecurity program
- Management develops a laboratory biosecurity risk statement, documenting which laboratory biosecurity scenarios represent an unacceptable risk and must be mitigated vs. those risks appropriately handled through existing protection control.
- Management develops a laboratory biosecurity plan to describe how the institution will mitigate those unacceptable risks including:
  - A written security plan, standard operating procedures, and incident response plans
  - Written protocols for employee training on potential hazards, the laboratory biosecurity program, and incident response plans.
  - Management ensures necessary resources to achieve the protection measures documented in the laboratory biosecurity plan.

**Step 5:** Re-evaluate the Institution's Risk Posture and Protection Objectives

- Management regularly re-evaluates and makes necessary modifications to the:
  - Laboratory biosecurity risk statement
  - Laboratory biosecurity risk assessment process
  - Institution's laboratory biosecurity program/plan
  - Institution's laboratory biosecurity systems.
- Management assures the daily implementation, training, annual re-evaluation and practice drills of the security program

## 8.2 Inventory Control

A comprehensive program of accountability is necessary to establish adequate control of at-risk biological agents, and to discourage theft and/or misuse. Laboratory shall have a procedures that can be used to achieve this include:

- Compilation of a detailed inventory, including description of the biological agent(s),
- Its quantities, storage location and use, the person responsible, documentation of internal and external transfers
- Any inactivation and/or disposal of the materials.
- A periodic review is recommended, and any discrepancies should be investigated and resolved.



- The biological agent inventory should be up-to-date, complete, accurate and updated regularly to ensure that there is appropriate control and accountability.

### **8.3 Information Control**

- Laboratory should have a procedure that can be used to protect the confidentiality and integrity of sensitive information held in the laboratory that could be used with malicious intent.
- Sensitive information should be identified, labeled and protected against unauthorized access.
- Sensitive information such as research data, diagnostic results, information on animal experiments, lists of key personnel (e.g. IT and biosafety contacts), security plans, access codes, passwords, storage locations and biological agent inventories must be protected.
- Sharing sensitive information with unauthorized individuals must be strictly prohibited.

### **8.4 Personnel Control**

- The effectiveness of any procedural controls for biosecurity should be determined by the training, capability, reliability and integrity of the personnel.
- Daily work practices and procedures should be performed by suitable personnel who behave in a reliable and trustworthy manner.
- Laboratory access request and approval processes for visitors and other outside personnel must be established to ensure that there is a legitimate need for access, and that appropriate vetting and escorting procedures are followed.
- Laboratory biosecurity training should be provided for all personnel according to the outcomes of the risk assessment.
- Security- related roles and responsibilities of personnel in everyday and emergency scenarios should also be defined.
- Succession planning should be in place for management, scientific, technical and administrative personnel to ensure that critical knowledge of the safe and secure operation of the facility does not lie with just one individual in the event of his/her unavailability or departure.
- Documented procedures for terminated or departing personnel must be established (e.g. transfer of accountability for inventories and equipment, retrieval of property belonging to the laboratory, cancellation of access).

## 8.5 Physical Security Control

- Physical security countermeasures are used to prevent unauthorized access of outside adversaries and also, to minimize the threat from insiders (i.e. those who have a legitimate presence in the facility such as employees and approved visitors) who do not require access to a particular asset.
- A physical security system should incorporate a variety of elements to enhance a facility's capability to deter, detect, assess, delay, respond to, and recover from a security incident.
- The security system should include boundaries, access controls, intrusion detection, alarm assessment and response, and should be graded. A graded protection system increases security incrementally and forms risk-based layers of protection around the facility's assets.
- The highest level of protection should be given to those assets whose loss, theft, compromise, and/or unauthorized use will have the most damaging effect on national and potentially international security, and/or the health and safety of employees, the public, and the environment.
- A physical security system should be selected and implemented after a site-specific biosecurity risk assessment.

## 8.6 Transport Control

- The laboratory should have procedures that ensure safe transport of biological agents.
- The transfer of biological agents must comply with national and international regulations for packaging, marking, labelling and documentation of transfer and transportation of biological agents.
- Transfers should be prearranged and preapproved by responsible parties and can use chain of custody documentation (or equivalent) for proper record-keeping if necessary, based on the outcomes of a biosecurity risk assessment.
- Inventories must be updated to reflect incoming and outgoing samples, including internal and external transfers.

## 8.7 Emergency/Incident Response Plan

- The laboratory should have procedures and plan for Emergency/incident response to ensure:
  - Effective incident response that can reduce the consequences of unknown events
  - Proper reporting, and to facilitate investigation, root-cause analysis, corrective action and process improvement.

- Drills and exercises can also be used in the planning and preparation stages to test the responses to simulated incidents or emergencies, identify gaps and other improvement opportunities
- Plans should be reviewed and updated at least annually and the information obtained through drills, incident reports and investigations should be used to make necessary adjustments and improvements.

## **8.8 Emerging Biotechnology Control**

Emerging biotechnology includes genetically modified microorganisms, synthetic biology, gain-of-function research, stem cell research, gene editing and gene drives. Advances in life sciences research are inextricably linked to improvements in human, plant and animal health.

- Research should be conducted responsibly, safely and securely
- Laboratories and scientists must consider the risks posed by incidents and/or the potential deliberate misuse of research and select appropriate control measures to minimize those risks in order to conduct necessary and beneficial research.
- Each institution shall assess the potential deliberate misuse of technology (genetically modified microorganisms, dual use research of concern, synthetic biology, gain-of-function research, stem cells, gene editing, and gene drives) and take appropriate action
- Conduct risk assessment for emerging technologies, and as additional information is obtained over time, contribute to better understanding of their risks and biosafety/ biosecurity needs
- Monitor and assess the scientific, ethical and social implications of certain biotechnologies
- Monitor the development of those technologies and their integration into scientific and clinical practice.

## **8.9 Dual Use Research of Concern**

Dual use research of concern is a research that, based on current understanding, has the potential to provide knowledge, information, products or technologies that could be directly misapplied to create a significant threat with potential consequences to public health and safety, agricultural crops and other plants, animals, and the environment.

- Awareness of the dual use of agents, equipment and technology should be considered in the development of laboratory biosecurity programmes

- Laboratories should take responsibility for the dual-use nature of such agents and experiments, such as genetic modification, and follow national guidelines in order to decide on the adoption of appropriate biosecurity measures to protect them from unauthorized access, loss, theft, misuse, diversion or intentional release.

## **8.10 Select Hazardous Pathogens and Toxins**

Select Hazardous Pathogens and Toxins are biological agents and toxins that have been determined to have the potential to pose a severe threat to public health and safety, to animal and plant health, or to animal or plant products. Biological materials currently have the potential for misuse and could be developed and employed as weapons of mass destruction due to the advancement of technologies. Clearly, there is a genuine and legitimate concern that laboratories working with select agents and toxins should receive special security and safety attention that other types of biological research would not require. Even though many of the materials on the select agent list may be found in natural environments, some laboratories maintain purified strains of the most dangerous pathogens. In addition, laboratory workers not only have access to these materials but also may possess the technical knowledge of how to grow them in the laboratory, although not necessarily the technical knowledge needed to weaponize them. So it is important to develop an effective strategy to control the selected agents and toxins. As a result of this, several countries developed regulations to regulate the possession, use, and transfer of select agents and toxins.

Likewise, the Ethiopian government is also working to establish Ethiopia's Select Hazardous Pathogens and Toxins (ESHPT) Regulatory Office that is given the authority to implement the requirements and is able to conduct all such actions as are necessary for the implementation of the requirements. These requirements are established and implemented for the purpose of validating, certifying, and monitoring the safe and secure facilities and practices of any biological institution or entity possessing, using, or transferring ESHPT. Implementing these requirements is in support of Ethiopia's implementation of the 1972 Biological and Toxin Weapons Convention (BWC) and the biological weapons-related provisions of UN Security Council Resolution 1540. The ESHPT Regulatory Office will identify and publish a list of ESHPTs and regulate the possession, use, and transfer of select hazardous pathogens and toxins so that important work with potentially dangerous and deadly pathogens and toxins is conducted as safely and securely as possible in Ethiopia.

### **8.10.1 Criteria for Inclusion of Agents and Toxins into the Hazardous Pathogens and Toxins List**

There are multiple factors that are considered before adding an agent to the select agent list. Simply having the potential to pose a significant threat to public health and safety. Select Agent status has generally been conferred on an *ad hoc*, case-by-case basis, using a combination of the following considerations:

- Virulence, pathogenicity, or toxicity of the organism; its potential to cause death or serious disease.
- The availability of treatments such as vaccines or drugs to control the consequences of a release or epidemic.
- The transmissibility of the organism; its potential to cause an uncontrolled epidemic.
- The ease of preparing the organism in sufficient quantity and stability for use as a bioterrorism agent; for example, the ability to prepare large quantities of stable microbial spores.
- Ease of disseminating the organism in a bioterrorism event to cause mass casualties, for example by aerosolization.
- Public perception of the organism; its potential to cause societal disruption by mass panic.
- Known research and development efforts on the organism by national bioweapons programs.

### **8.10.2 Requirements for Health Facilities Handling Select Hazardous Pathogens and Toxins**

The laboratories/health facilities that handle, use, and store select hazardous pathogens and toxins should ensure the following:

- The laboratory should develop and implement a written security plan. The security plan must be sufficient to safeguard the agent or toxin against unauthorized access, theft, loss, or release. The plan must be designed according to a site-specific risk assessment and should provide graded protection in accordance with the risk of the agent or toxin, given its intended use.
- The laboratory should have biosafety and containment procedures sufficient to contain the agent or toxin (e.g., physical structure and features of the facility, and operational and procedural safeguards).
- The laboratory should have a biosafety plan that includes an occupational health program for individuals with access to agents and toxins, and those individuals must be enrolled in the occupational health program. Medical clearance should be provided before the start of employment and after placement periodically.

- The biosafety plan must be reviewed annually and revised as necessary. Drills or exercises should be conducted periodically to test and evaluate the effectiveness of the plan. The plan must be reviewed and revised, as necessary, after any drill or exercise and after every incident.
- The laboratory should have an incident response plan, and the plan should fully describe the laboratory's response procedures for the theft, loss, or release of an agent or toxin; Inventory discrepancies; security breaches (including information systems); severe weather and other natural disasters; workplace violence; human accidental exposure; intentional pathogen and toxin exposure; and suspicious packages are all examples of potential hazards.
- The laboratory should have an incident response procedure that should account for hazards associated with the agent and/or toxin and appropriate actions to contain such agents and/or toxin, including any animals (including arthropods), humans, or plants intentionally or accidentally exposed to or infected with an agent.
- Training should be provided for individuals handling and working on select hazardous pathogens and toxins periodically on how to use, store, and safely dispose of them.
- The laboratory should have a biosafety and biosecurity officer. The biosafety and biosecurity officer should ensure the implementation of biosafety and biosecurity requirements, training provided to each individual with access to agents and toxins, and maintenance of records.
- Hazardous pathogens and toxins should be stored in a secure and restricted area.
- The laboratory should have an updated inventory record for all select hazardous pathogens and toxins and conduct complete inventory audits of all agents and toxins in long-term storage when any of the following occurs:
  - Upon the physical relocation of a collection or inventory of agents or toxins for those agents or toxins in the collection or inventory;
  - Upon the departure or arrival of a responsible person for those agents and toxins under the control of that principal investigator; or
  - In the event of a theft or loss of an agent or toxin, all agents and toxins are under the control of that responsible person.
- The hazardous pathogens or toxins should only be transferred to facilities that have the mandate and capacity to possess and use that hazardous pathogens or toxins. Any facility should request officially to get hazardous pathogens or toxins and the request must be authorized by the health facility official or director prior to the transfer.

## Chapter 9: Transportation of Biological Hazardous Substances

During transportation of biological substances; health facilities should adhere to local, national and international regulations for safe and secure transportation. Shipment of biological substances comes with a lot of challenges that emanate from poor labeling, packaging and documentation, incompetent courier, and failure to maintain cold chain system. Packaging of infectious materials must be designed properly to minimize potential exposure of hazard during transportation. It is only through adherence to the prescribed shipment procedure that the biological substances specimens can reach the consignee and be analyzed at a near 'original' condition after prolonged transit period.

Before transportation of specimens, the following shall be adhered to;

- Ensure the Packaging is properly done.
- Labelling of all the packages shall include the address, biohazard, and package orientation. .
- Transportation of the packages at the right temperature range, right period of time and all other specimen requirements to ensure the integrity of the specimens is maintained.
- A completely filled tracking form to ensure the biological substance are not lost.
- Sender and/ or, Shippers and couriers are trained on national and international regulations how to properly pack, label, and transport to recognize and respond to the risks posed by the transported biological materials.

### 9.1 Standard Techniques for Safe Management of Biological Hazardous Substances

#### 9.1.1 Handling of Biological Hazardous Substances

The precautions that should be taken during biological hazardous substances collection are.

- Laboratory personnel performing specimen collection shall be trained on biological hazardous substance management in consideration of safety and decontamination techniques
- The personnel should use PPE during handling of biological hazardous substance
- Puncture resistance, leak-proof and securely capped container shall be used for handling of biological hazardous substance to prevent leakage and spread of infection
- The biological hazardous substances should be handle based on the protocol set for biological hazardous substance type
- Biological hazardous substances containers shall preferably be plastic, robust and should not leak when the cap or stopper is correctly applied.

## 9.1.2 Transportation of Biological Hazardous Substances

When transporting biological hazardous substances, the sender must determine whether the material is a dangerous goods or not. Dangerous goods are materials that can

- harm humans,
- animals and other living organisms,
- property, or the environment,

And their transportation is controlled by United Nations (UN) regulations.

As biological hazardous substances are classified under dangerous goods, they are assigned a UN number and proper shipping name based on the classification of the dangerous goods

### 9.1.3 Categories of Infectious Substance

According to their hazard classification and their composition dangerous goods are assigned UN number and proper shipping names. In this regard infectious substances are classified under Class 6: Toxic and Infectious Substances in Division 6.2. Based on their disease causing potential and type, the infectious substances categorized into Category A and Category B.

#### 9.1.3.1 Category A

A Category A substance is an infectious substance which is transported in a form that, when exposure to it occurs, is capable of causing permanent disability, life-threatening or fatal disease in otherwise healthy humans or animals. Two UN numbers and proper shipping names are associated with Category A infectious substances

- Infectious substances capable of causing disease in humans, or both humans and animals, are assigned to **UN 2814**, and given the proper shipping name of **Infectious substance affecting humans**. Infectious substances capable of causing disease only in animals are assigned to **UN 2900**, and given the proper shipping name of **Infectious substance affecting animals only**.
- Medical wastes containing: Category A infectious substances must be assigned to UN 2814, UN 2900 or UN 3549, as appropriate.
- Solid medical waste containing Category A infectious substances generated from the medical treatment of humans or veterinary treatment of animals may be assigned to UN 3549.
- Medical devices or equipment potentially contaminated with Category A infectious substances must be assigned to **UN 2814**, UN 2900 or **UN 3549**, as appropriate.



### **9.1.3.2 Category B**

These categories contain biological agents capable of causing infection in humans or animals, but not meeting the criteria for Category A; that is, the consequences of an infection are not considered severely disabling or life-threatening. The following UN numbers and proper shipping names are associated with Category B infectious substances:

- The UN number and proper shipping name for most shipments of Category B infectious substances is UN 3373, Biological substance, Category B.
- Medical or clinical wastes containing: Category B infectious substances must be assigned to UN 3373. However, medical or clinical wastes which are reasonably believed to have a low probability of containing infectious substances must be assigned to UN 3291.
- Medical devices or equipment potentially contaminated with Category B infectious substances must be assigned to UN 3373.

### **9.1.3.3 Exemption Substances**

There are some circumstances where, although the material or product being shipped falls under one of the categories, it will not meet the definition for an infectious substance due to the confirmed absence of biological agents, or that the fact that any biological agents present are known to be incapable of causing disease in humans or animals (i.e. non-pathogenic or inactivated or neutralized through a decontamination process). In such cases,

These substances have been neutralized or inactivated such that they no longer pose a health risk, or that do not contain infectious substances to cause disease in human or animals.

- substances containing organisms that are non-pathogenic
- substances containing neutralized or inactivated pathogens
- biological materials that do not contain infectious substances
- biological materials containing microorganisms that are non-pathogenic to humans or animals; environmental samples that pose no risk of infection
- blood or blood components collected for transfusion
- tissues or organs cleared for transplantation
- decontaminated medical or clinical waste

Table 8: Summary of classification, categorization, identification and packaging of infectious substances and contaminated items with infectious substances.

Dangerous goods classifications	Categorisation	Proper shipping name <sup>2</sup>	UN number <sup>2</sup>	Packing instruction/packaging requirements
<b>Class 6, Division 6.2</b>	Category A	Infectious substance, affecting humans	UN 2814	P620
		Infectious substance, affecting animals	UN 2900	
		Medical* devices or equipment contaminated with or containing infectious substances in Category A	UN2814, UN2900 UN 3549	Must be marked "Used Medical Device" or "Used Medical Equipment"
		Medical* waste, Category A, affecting humans, solid; or Medical waste, Category A, affecting animals only, solid	UN 2814, UN 2900 UN 3549	P622, LP622
<b>Class 6, Division 6.2</b>	Category B	Biological substance, Category B	UN 3373	P650
		Clinical waste, medical or clinical wastes which are reasonably believed to have a low probability of containing infectious substances	UN 3373 UN3291	P621 (PI622), IBC620, LP621
<b>Class 6, Division 6.2</b>	Exempt human/animal specimens	Exempt human/animal specimens	N/A	Triple packaging
		Medical* devices, medical equipment	N/A	See UN Model Regulations 2.6.3.2.3.9 and IATA Dangerous Goods Regulations (DGR) 3.6.2.2.3.9
<b>not subject to dangerous goods regulations</b>	Biological materials not subject to dangerous goods regulations	N/A	N/A	N/A
<b>Class 9</b>	Genetically Modified Organisms (GMOs) that are not classified as Category A or B infectious substances	Genetically modified microorganisms; Genetically modified organisms	UN 3245	P904 (ICAO/IATA PI 959), IBC99

- If it is likely that microorganisms that are present in the biological materials can cause harm to humans or animals then they must be assigned either to Category A or B.
- The proper shipping name (in the Table) must be supplemented with the technical name (scientific name of the pathogen) in parenthesis on the transport document, but not on the outer packaging.
- When the identity of the infectious substances to be transported are unknown, but are suspected of meeting the criteria for inclusion in category A, the words “suspected category A infectious substance” must be shown, in parenthesis, following the proper shipping name on the transport document.

#### **9.1.4 Biological Hazardous Substance Transport Containment System**

Specimens shall be transported in a containment system

- Place all liquid biological hazardous substance in containers that will prevent leakage during transport.
- Primary container with screw cap/ properly fit stopper top, leak proof and appropriately labelled as to content. It should be wrapped in enough absorbent material to absorb all fluid in case of breakage or leakage.
- Secondary container must be water tight and leak proof or sift proof packaging to enclose and protect the primary receptacle and a requisition paper placed in outside pouch of biohazard bag
- Tertiary container should be protective for the secondary packaging from physical damage while in transit
- Use transport boxes (Styrofoam with fibreboard, plastic, or metal) and ensure lid is securely fastened
- Package 20-30 biological hazardous substance per box, pack specimens vertically to avoid leaking.
- Use cold chain or room temperature transport and keep specimens protected from light.

Mailing infectious substances by air also falls under the *Dangerous Goods Regulations* (DGR) of the International Air Transport Association (IATA) [[www.iata.org](http://www.iata.org)]. These regulations set out all the International Civil Aviation Organization (ICAO) mandates and the airline industry’s universal rules on how to safely package and transport infectious substances.

The following criteria must meet:

- Containers should be clearly labeled on the side, not the cap
- Identification number on each specimen container corresponds to the identification number on the specimen log

- Request forms must be separated from specimen container
- Specimen log should include the requested data for each patient
- Do not wrap specimen request or specification forms around containers.
- Number of specimen containers in the box must be corresponds to the number of names on the specimen log
- Close plastic bags used for transporting specimens with twist ties or zip-locks.  
DO NOT Use Staples, Pins or Needles as they are a common cause of injury when attempting to open bags.
- Date shipped and the name of the health facility are included on the specimen log.

### **9.1.5 Packaging**

All biological materials should be packaged and transported in accordance with local, national and international regulations. The procedures should minimize the risk of exposure for those engaged in transportation and should protect the community, the environment and susceptible animal populations from potential exposures.

Biological materials should always be packaged and transported to protect the integrity of the specimens, as well as to avoid cross-contaminating other specimens and environmental contamination. Minimum requirements for the transport of specimens follow the principle of triple packaging, consisting of three layers as described below:

- a primary receptacle;
- a secondary packaging;
- a Third (outer) packaging;

Of which either the secondary or the outer packaging must be rigid.

#### **9.1.5.1 Primary Receptacle**

A primary receptacle, leak-proof for liquids or sift-proof for solids containing the specimen. Primary receptacle(s) must be packed into the secondary packaging with enough absorbent material (e.g. cellulose wadding, paper towels, house hold paper, cotton balls) to absorb all fluid in case of breakage. Even though the regulations do not prohibit glass, primary receptacles should preferably be non-breakable. In addition, they must not contain any sharps (e.g. vacutainer with needle), particularly when using soft secondary or outer containers. If screw cap vials are used, they shall be secured by e.g. Tape. A flip-top vial must not be used.

### 9.1.5.2 Secondary Container

A secondary container is a durable, leak-proof packaging that surrounds and protects the primary receptacle(s) (for example, a sealed plastic bag, plastic container, or screw-cap can). The primary receptacle or the secondary packaging shall be capable of withstanding, without leakage, an internal pressure of 95 kPa (0.95 bar) in the range of -40°C to +55°C (-40°F to +130°F).

### 9.1.5.3 Third (Outer) Packaging

The third packaging must be rigid and the smallest external dimension shall be not less than 100 mm. An itemized list of contents shall be enclosed between the secondary container and outer packaging, including the proper shipping name and technical name in parentheses of the biological agent present in the infectious substance. Secondary packaging is placed in outer shipping packaging (e.g. sturdy insulated fiber board box) with suitable cushioning material. Outer packaging protects the contents from outside influences, such as physical damage, while in transit.

### 9.1.5.4 Packaging of Category A

Due to the highly hazardous nature of the Category A samples the packaging must meet special requirements. The principle of triple packaging applies here, and the transport containers and outer packaging must meet the criteria defined in the relevant regulations. Category A must only be transported in packaging that meets the United Nations class 6.2 specifications, complies with Packing Instruction P620 and have passed specific tests and with UN specification marking as P620 (see figure 8).

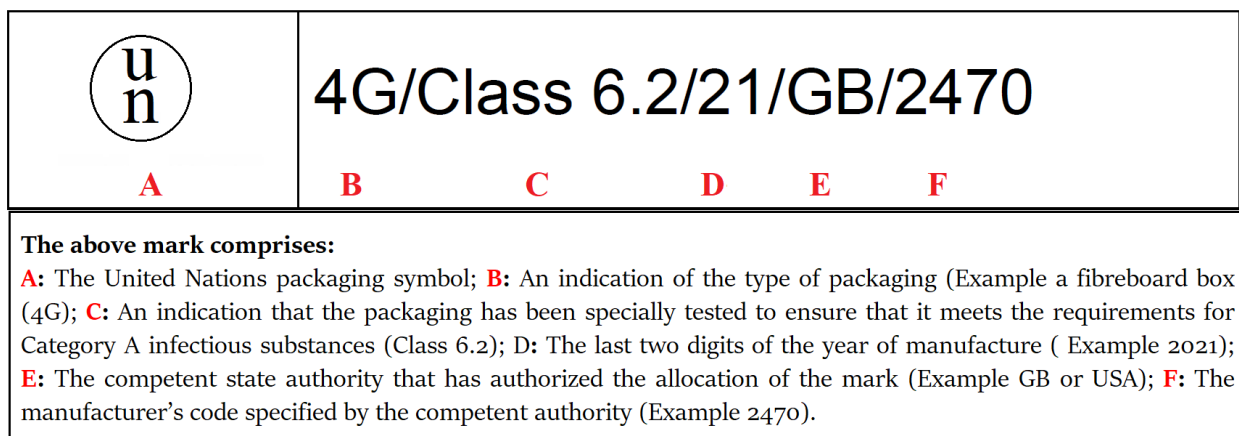

Figure 8: A description of the features of the UN specification mark for category A infectious substances packaging (for UN 2814 and UN 2900).

This ensures that strict performance criteria are met; tests for compliance with these criteria include a 9-metre (29.5 feet) drop test, a puncture test, a pressure test and a stacking test. The packages are labeled to

provide information about the contents of the package, the nature of the hazard and the packaging standards applied (figure 9).



Figure 9: Sign that labeled with packaging of category A

Marking and labeling is as follows

- i. The delivery address (consignee) and sender's details (shipper), as well as 24/7 emergency contact details including named persons with telephone numbers to guarantee safe delivery.
- ii. The proper shipping name and the UN number.
- iii. The Infectious Substance label
- iv. UN specification marking for P620 packaging (printed on the box).
- v. Orientation label, Cargo only label, if required (depending on the Net Weight [kg] of the infectious substance in a P620 box).
- vi. Color: Black OR Red arrows on a white, or suitably contrasting, background (figure 10)

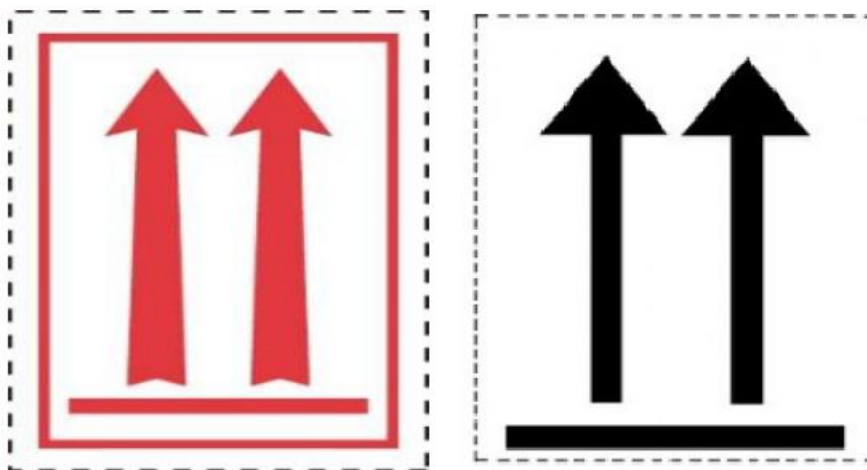

Figure 10: Orientation arrows with recommended colors

#### 9.1.5.4.1 Packaging for Air Transport

- i. The primary receptacle or secondary packaging must be capable of withstanding, without leakage, an internal pressure of 95 kPa. The primary receptacle or secondary packaging must also be capable of withstanding temperatures in the range of  $-40^{\circ}\text{C}$  to  $+55^{\circ}\text{C}$ ;
- ii. For liquids: the net quantity of infectious substances per one P620 box shall not exceed 50 ml for transport in cargo space of a passenger aircraft; and must not contain more than 4 liters (contain multiple primary receptacles with a total of more than 4 liters) for transport on a cargo only aircraft;
- iii. For solids: the net quantity of infectious substances per one P620 box shall not exceed 50 g for transport in cargo space of a passenger aircraft, and must not contain more than 4 kg (even if containing multiple primary receptacles totaling more than 4 kg) for transport on a cargo only aircraft. This quantity limit doesn't apply for animal parts, organs and whole carcasses.
- iv. The three triple packaging principle has to be adopted accordingly using appropriate packaging systems;
- v. The entire package must be tested and complies with Packing Instruction P620 see figure 11.

For further information on marking and labeling of the Category A shipment package, see P620 Packing Instruction for UN Number 2814 and 2900.

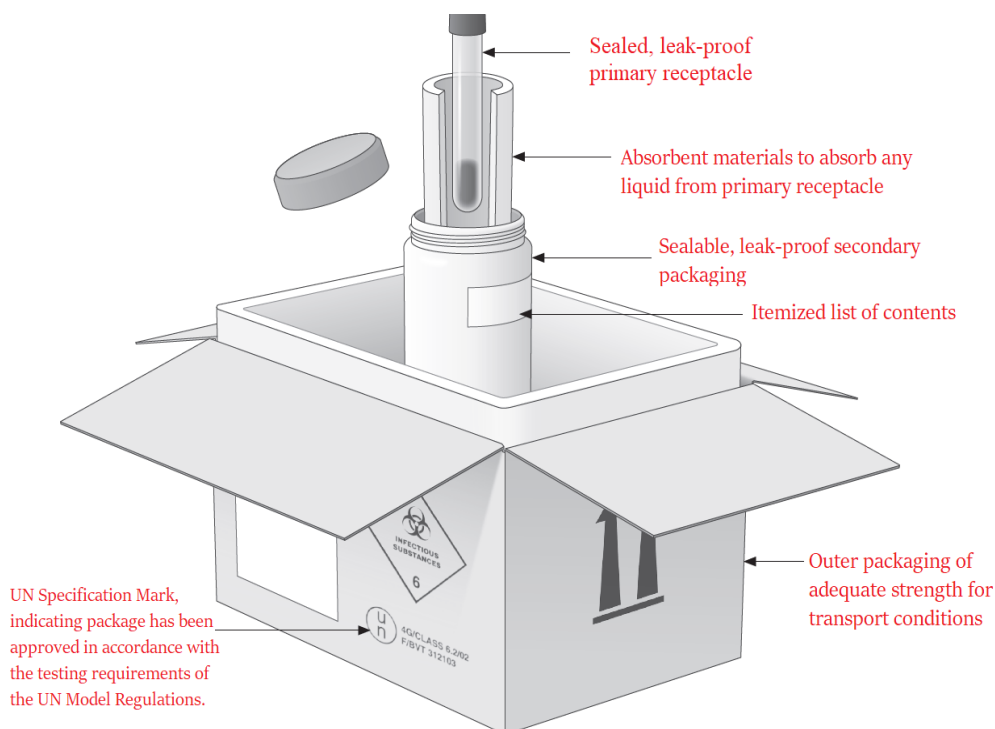

Figure 11: A triple package content for category A infectious substances (Adopted from WHO)

### 9.1.5.5 Packaging of Category B

Category B must be transported in a packaging that complies with the requirements of packing instruction P650. The approval of the box by the government is not required, thus UN specification marking is not required. Marking is as follows:

- i. Packages should be clearly labeled with the delivery address and sender's details to guarantee safe delivery in time at the correct destination.
- ii. Label with the proper shipping name in letters at least 6 mm high: "BIOLOGICAL SUBSTANCE, CATEGORY B" .
- iii. In addition to the proper shipping name, the mark (UN3373 in diamond) is used for shipments of Category B substances. The UN3373 mark must always be visible on the outer packaging see figure 12. Additional requirements do apply as for category A for international shipment and air transport. One of the main differences between P650 and P620 is the reduced drop-test to 1.2 meters (4 feet).

#### 9.1.5.5.1 Packaging for Air Transport

- iv. The primary receptacle or secondary packaging must be capable of withstanding, without leakage, an internal pressure of 95 kPa. The primary receptacle or secondary packaging must also be capable of withstanding temperatures in the range of  $-40^{\circ}\text{C}$  to  $+55^{\circ}\text{C}$ ;
- i. For liquids: no primary receptacle shall exceed 1 litre and the outer packaging must not contain more than 4 liters (contain multiple primary receptacles totaling more than 4 litres);

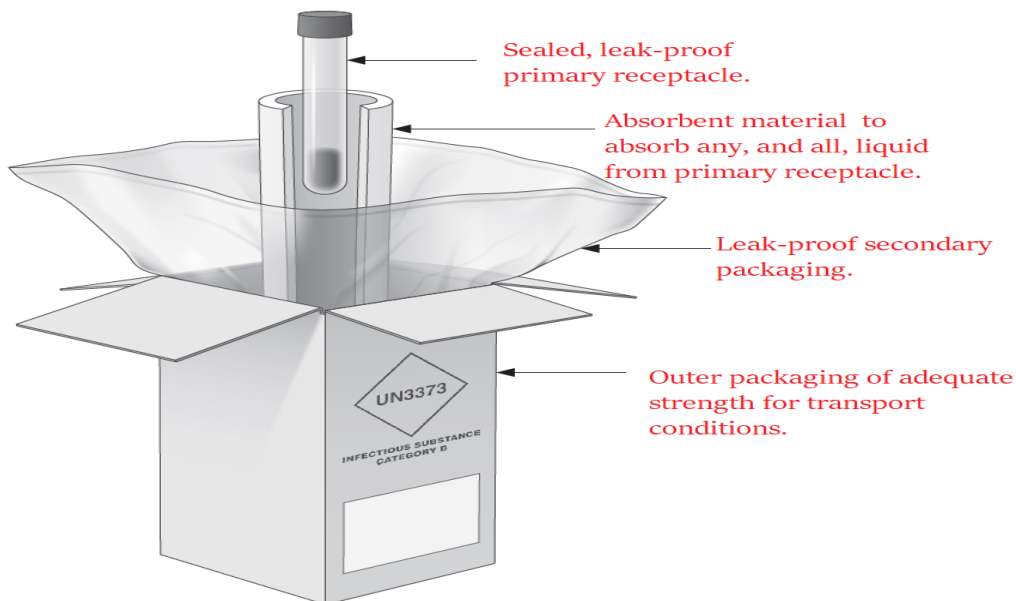

Figure 12: A triple package content for category B infectious substances (Adopted from WHO)



- ii. For solids: the outer packaging must not contain more than 4 kg. This restriction doesn't apply for animal parts, organs and whole carcasses. The exact details can be found in P650 Packing Instruction for UN No. 33737.

#### **9.1.5.6 Packing of Exempt Specimen**

Biological materials for which there is a minimal likelihood that pathogens are present are not subject to regulation if the specimen is carried in a packaging which will prevent any leakage and which is marked with the words "Exempt animal or human specimens", as appropriate. The triple packaging system must still be applied and it must consist of three components: a leak-proof primary receptacle, a leak-proof secondary packaging and an outer packaging of adequate strength for its capacity, mass and intended use and with at least one surface having minimum dimensions of 100 mm × 100 mm.

- For liquids, absorbent material in sufficient quantity to absorb the entire contents must be placed between the primary receptacle(s) and the secondary packaging so that, during transport, any release or leak of a liquid substance will not reach the outer packaging and will not compromise the integrity of the cushioning material.
- Once contained in an appropriate triple packaging system, exempt specimens are not subject to any other infectious substances regulations. For more detailed information on the components of an appropriate triple packaging system, please refer to Section 6.2. on packaging.

#### **9.1.5.7 Biological Materials Not Subject Dangerous Goods Regulations**

This exemption refers to biological materials that do not contain infectious substances and are therefore not subject to dangerous goods regulations (such as class 6.2) and any packaging requirements, unless they meet the criteria for inclusion in another class (such as class 9).

Note: There may be specific regulations in place in some countries for the shipment, export or import of nucleic acids. Packaging for biological materials not subject to dangerous goods regulations such as GMOs can also be shipped with a label of UN 3245 and it needs to have a labeling mark indicated in figure 14

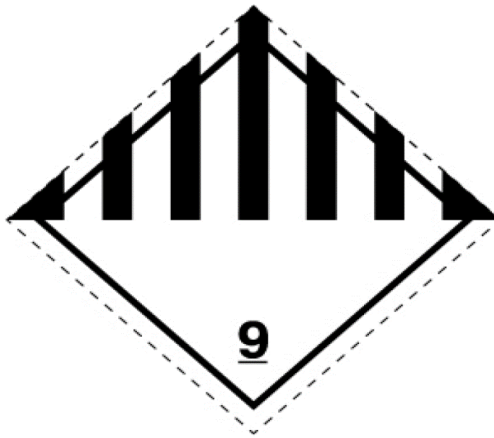

Figure 13: Hazard labels applicable to infectious substances shipments

#### **9.1.5.8 Over Pack**

“Over pack” is the term used when two or more packages are combined to form one unit and sent to the same destination by a single shipper. When refrigerants are used to protect contents, the over packs may comprise insulated vessels or flasks. Whenever an over pack is used, the required marks and labels shown on the outer packaging must be repeated on the outermost layer of the over pack, except for the UN specification marking on P620. This requirement applies to all infectious substances including Categories A and B. Over packs are also required to be marked with the word “over pack”. Combining different categories of infectious substance in a same over pack is permissible however in this case outer labeling should indicate the highest category included in the package.

- The secondary receptacle shall be secured within the outer package to maintain the original orientation of the inner packages after the refrigerant has melted or dissipated.
- If liquid nitrogen is used as a refrigerant, additional requirements have to be followed according to the relevant regulations for dangerous goods (Division 2.2, UN 1977).

Information on Dry Shipper is available in p19 of WHO Guidance on regulations for the transport of infectious substances 2017–2018.

### **9.2 Guidance for Spill Management during Sample Transportation.**

In day-to-day transport of specimens, breakage of containers and spillage of specimens may occur inadvertently. Although the risk of exposure to infectious substances is minimal, a courier staff should receive appropriate training for safe handling and spill management.

## 9.2.1 Handling of Specimen Spillage during Transport

1. Biological Spill Kit
  - A biological spill kit should be available in the vehicle if a large number of specimens are transported using a designated vehicle.
  - For transporting a small number of specimens not using a designated vehicle, a prepackaged bag containing gloves, disposable absorbent material, a small bottle of ready-to-use disinfectant, an alcohol-based hand hygiene product, and a clinical waste bag would be appropriate for cleanup of a minor spillage.
2. Report any spillage incident to supervisor.
3. Clean up the spill as soon as possible as follows:
  - Alert people in the area of the spill to evacuate.
  - Remove and disinfect any material that has been splashed on you and remove/disinfect grossly contaminated clothing.
  - Secure the affected area and post biohazard-warning signs.
  - Assess the situation and don the appropriate personal protective equipment for the cleanup operation
  - Cover the spill with absorbent material (e.g., cloth or paper towels) to contain it.
  - Pour disinfectant over the cloth or paper towels and the immediate surrounding area. Apply the disinfectant concentrically, beginning at the outer margin of the spill area, working towards centre.
  - Wait at least 15 minutes for the disinfectant to penetrate through the contained spill and achieve the required contact time for disinfection .(always follow the manufactures instruction)
  - Using the appropriate tools (i.e., shovels, forceps), remove the absorbent material and place it in a biohazard bag for autoclaving and subsequent disposal.
  - Repeat Spill Cleanup Procedure over the original spill area to ensure disinfection and cleanup.
  - Remove gloves (and other personal protective equipment if used), taking care not to contaminate yourself, and wash your hands (or perform hand hygiene using an alcohol-based product if there is no visible contamination)
  - In case of major spill:
    - Alert people in the area of the spill to evacuate and eliminate entrance of additional personnel via notification or posting of area.

- If any material has been splashed on you, immediately wash the exposed area with soap and water. If the exposed area is the eye, flush with water only for 15 minutes and remove and disinfect any contaminated clothing.
- Notify your supervisor of the incident.
- If the situation involves an imminently life-threatening injury or has other catastrophic potential, contact responsible body.
- Request support from persons knowledgeable of incident

### **9.2.2 List of Items in the Biological Spill Kit**

The following items should be included in the biological spill kit for the designated vehicle for transporting specimens.

1. Disposable latex gloves
2. Disposable protective gowns
3. Face/eye protection devices
4. Surgical mask
5. Disposable absorbent materials such as paper towels or cloth
6. Disposable waste bags (red) for clinical waste
7. Ready-to-use disinfectant (e.g. 1 part of household bleach in 4 parts of water)\*
8. Hand hygiene products (e.g. alcohol-based hand-rubs)

Other ready-to-use disinfectant products can be used. The disinfectant must be prepared according to the instructions by the manufacturer and must be replaced when it expires after preparation.

## Chapter 10: Waste Management

Healthcare waste is any kind of waste containing infectious waste and other hazardous materials which includes all the waste generated within health-care facilities, research centers and laboratories related to medical procedures. It may also include waste associated with the generation of biomedical waste that visually appears to be of medical or laboratory origin as well research laboratory waste containing biomolecules or organisms that are mainly restricted from environmental release.

According to WHO, up to 25% of health-care waste is hazards and may pose a variety of health and environmental risks. Laboratory waste is a potential reservoir of pathogenic microorganisms and therefore requires appropriate safe handling and disposal.. Safe management of healthcare waste (HCW) is a key issue in controlling and preventing laboratory/hospital acquired infections (LAIs). Each laboratory shall have a waste management plan that entails, segregation, collection, packaging, storage, transportation, treatment and disposal of waste. The plan shall be able to outline the treatment of regulated and non-regulated waste from health facilities, especially laboratories. Laboratory/healthcare wastes and contaminated materials pose hazards to healthcare professionals, supportive staff, the community, and the environment. In addition to this guideline, the Ministry of Health Ethiopia has developed a manual called the Health Care Waste Management Manual for Ethiopia, which encourages all health facilities to use it.

### 10.1 Types of Health-Care Waste

As laboratory facilities perform several laboratory and research activities, there are different types of wastes generated as indicated in the table below:

Table 9 : Type of hazardous health-care waste

Waste category	Descriptions and examples
Infectious waste	Waste suspected to contain pathogens and that poses a risk of disease transmission (e.g. waste contaminated with blood and other body fluids; laboratory cultures and microbiological stocks; waste including excreta and other materials that have been in contact with patients infected with highly infectious diseases in isolation wards)

Sharps waste	Used or unused sharps (e.g. hypodermic, intravenous or other needles; auto-disable syringes; syringes with attached needles; infusion sets; scalpels; pipettes; knives; blades; broken glass)
Pathological waste	Pathological waste consists of tissues, organs, body parts, blood, body fluids and other waste from surgery, pathological examination and autopsies on patients with infectious diseases. It also includes infected animal carcasses.
Pharmaceutical waste, cytotoxic waste	Pharmaceuticals that are expired or no longer needed; items contaminated by or containing pharmaceuticals  Cytotoxic waste containing substances with genotoxic properties (e.g. waste containing cytostatic drugs – often used in cancer therapy; genotoxic chemicals)
Chemical waste	Waste containing chemical substances (e.g. laboratory reagents; film developer; disinfectants that are expired or no longer needed; solvents; waste with high content of heavy metals, e.g. guanidinium thiocyanate batteries; broken thermometers and blood-pressure gauges)
Radioactive waste	Waste containing radioactive substances (e.g. unused liquids from radiotherapy or laboratory research; contaminated glassware, packages or absorbent paper; urine and excreta from patients treated or tested with unsealed radionuclides; sealed sources)
Non-hazardous or general health-care waste	Waste that does not pose any particular biological, chemical, radioactive or physical hazard

## 10.2 Risks Associated with Health-Care Waste Handling

The large component of non-hazardous health-care waste is similar to municipal waste and should not pose any higher risk than waste produced in households. It is the smaller hazardous health-care waste component that needs to be properly managed so that the health risks from exposure to known hazards can be minimized. Protection of the health of staff, patients and the general public is the fundamental reason for implementing a system of health-care waste management. The hazardous nature of health-care waste is due to one or more of the following characteristics:

- presence of infectious agents
- presence of genotoxic or cytotoxic chemical composition

- presence of toxic or hazardous chemicals or biologically aggressive pharmaceuticals
- presence of radioactivity
- presence of sharps materials

All individuals coming into close proximity with hazardous HCW are potentially at risk of exposure. Health workers should understand the significance of each link and the means by which the chain of infection can be interrupted. Consequently, good healthcare waste management can be viewed as an infection-control procedure.

Thus, healthcare facility management is responsible for ensuring that personnel who handle healthcare waste have adequate knowledge about healthcare waste hazards, adhere to safety practices, and proper methods of handling healthcare waste.

### **10.3 Healthcare Waste Management**

Health- Healthcare facility management is responsible for ensuring that waste is kept under control at all times within a healthcare facility and disposed of safely either onsite or offsite. Proper segregation, onsite storage, and transportation systems from the point of generation of waste to its final treatment or disposal play an important role in the management of healthcare waste.

Healthcare facility management should ensure the following general principles of waste segregation, storage, and transportation related to the management of waste from generation to disposal:

- Health-care waste generated in a laboratory area should be segregated into different categories, based on their potential hazard and disposal route, by the person who produces each waste item;
- Separate containers should be available in each medical area for each segregated waste fraction;
- waste containers when filled should be labelled to help managers control waste production;
- Closed local storage inside or near to a medical area may be needed if wastes are not collected frequently;
- Hazardous and non-hazardous wastes should not be mixed during collection, transportation or storage;
- Collected waste is often taken to central storage sites before onsite or offsite treatment and disposal;
- Staff should understand the risks and safety procedures for the wastes they are handling.

### **10.3.1 Waste Minimization**

Waste minimization is the first and most important waste management step. It helps to ensure good sanitation of the facility and the safety of workers and communities by reducing the quantity of waste generated. Managing health-care waste safely requires clear objectives and planning at facility levels. The preferred management solution is simply not to produce waste by avoiding wasteful ways of working. To achieve lasting waste reduction, the focus should be on working with staff to change practices to ones that use fewer materials. Although waste minimization is most commonly applied at the point of its generation, healthcare managers can also take measures to reduce the production of waste through adapting their purchasing and stock control strategies. Some practices that encourage waste minimization.

Effective waste minimization practice requires that all purchases of materials and supplies be made with waste reduction in mind, meaning that materials and supplies should be purchased with the intent that they produce no or minimal waste. Some practices that encourage waste minimization are:

#### **Source reduction**

- Purchasing reductions: - selecting supplies where smaller quantities can be used, or that produce a less hazardous waste product.
- Use of physical rather than chemical cleaning methods (e.g. steam disinfection instead of chemical disinfection).
- Prevention of wastage of products (e.g. cleaning activities).

#### **Stock management of Chemical and Pharmaceutical Products**

- More frequent ordering of relatively small quantities rather than large amounts at one time, to reduce the quantities used (applicable in particular to unstable products).
- Use of the oldest batch of a product first.
- Use of all the contents of each container.
- Checking of the expiry date of all products at the time of delivery, and refusal to accept short-dated items from a supplier.

### **10.3.2 Healthcare Waste Collection and Segregation**

Segregation means the separation of the entire waste generated in the institution into different waste groups according to the specific treatment and disposal requirements. It must be performed at the point of



generation by the individual who generate/produce the waste, and collected separately from hazardous waste from non-hazardous waste on site to ensure safe and cost-effective disposal.

### **10.3.2.1 Segregation of Waste**

Proper segregation must follow standardized procedures to reduce the risk of infecting workers, and enable use of the most efficient treatment procedures for each waste stream. Segregation must:

- Be simple to implement for medical and ancillary staff
- Ensure the absence of infectious and hazardous HCW in the domestic waste flow
- Be applied in all health care facilities
- Be regularly monitored to ensure compliance

The following guidelines should be included for HCW segregation:

- Segregation of HCW should separate the different types of waste so that each can be handled safely and economically.
- Health care facilities should provide color coded waste receptacles specifically suited for each category of waste.
- The color-coding system aims for ensuring immediate and non-equivocal identification and segregation of the hazards associated with the type of HCW that is handled or treated. In this respect, the color coding system shall remain simple and be applied uniformly throughout the country. In the absence of color-coded bins, however, labelled waste bins with an infectious waste symbol or text can be used as an alternative to ensure safe segregation practices.
- Segregation shall take place at the source—at the ward bedside, operation theatre, medical diagnostic laboratory, or any other place where the waste is generated.
- The nine categories of HCW shall be segregated and color-coded as outlined in table 1 and table 2. Please refer to Annex II for further information on the nine categories of HCW.

### **10.3.3 Collection of Waste**

Using color-coded containers is preferable to identify hazardous waste easily and ensure its safe disposal. A health facility should provide a sufficient number and size of plastic bags and containers for the amount of waste generated. The waste container should be sturdy and leak-proof and lined with a sturdy plastic bag. The recommended thickness of bags for infectious waste is 70 µm (ISO 7765:2004). Plastics used for either

containers or bags should be chlorine-free. Not all plastic bags can withstand temperatures of 121 °C, and some can melt during an autoclave process. Therefore, select an autoclavable bag during autoclaving.

Containers should have well-fitting lids, either removable by hand or preferably operated by a foot pedal. Both the container and the bag should be the correct color for the waste they are intended to receive and labeled clearly. Mixing colors, such as having yellow bags in black bins, should be avoided, because it will increase the potential for confusion and poor segregation. Waste containers should be cleaned regularly to avoid the accumulation of waste and can be a source of infection too.

Since sharps can cause injuries that leave people vulnerable to infection, both contaminated and non-contaminated sharps should be collected in a puncture-proof and impermeable container that is difficult to break open after closure.

### 10.3.4 Color-Coding System

The following guidelines should be included for the color-coding system:

- Black: All bins or bags containing non-risk HCW.
- Yellow: Any kind of container filled with infectious HCW, including safety boxes.
- Red: Any kind of container filled with heavy metal or effluent
- White: Any container or bin filled with drug vials, ampoules, or glass bottles for glass recycling or reuse.
- This system is used only where a municipal glass recycling system is available. Open after closure.

Table 10: Waste segregation, collection and color coding and type of waste containers recommendation

Waste categories	Color of container & marking	Type of container	Collection frequency
Infectious waste	Yellow/Red with biohazard symbol (highly infectious waste should be additionally marked <b>HIGHLY INFECTIOUS</b> )	Leak-proof strong plastic bag placed in container (Bag for highly infectious waste should be capable of being autoclaved)	When filled to the line or 3/

Sharp waste	Yellow/Red marked <b>SHARPS</b> with biohazard symbol	Puncture-proof container	When filled to the line or $\frac{3}{4}$
Pathological waste including animal carcasses	Yellow/Red	Leak-proof strong plastic bag placed in container	When $\frac{3}{4}$ filled or at least once a day
Chemical and Pharmaceutical (Genotoxic) waste	Brown, labelled with appropriate hazard symbol	Plastic bag or rigid container	On demand
Radioactive waste	Labelled with radiation symbol	Lead box	On demand
General waste (Non- hazardous )	Black	Plastic bag inside a container	When $\frac{3}{4}$ filled or at least once a day

### 10.3.5 Packaging

Packaging of regulated waste can be described as containment of waste and is used to ensure the safety, protection of personnel and environment. This can be achieved by:-

- Ensuring all regulated waste is sealed properly with tape.
- Placing bags in upright position to prevent spillage of liquid.
- Storing regulated waste in approved red plastic bags that are impervious to moisture, puncture resistant, and display the distinctive biohazard symbol.
- Using durable reusable containers for storage of regulated waste and ensure containers are cleaned and decontaminated with approved disinfectant each time they are emptied.
- Using packaging that maintains its integrity during storage and transport.

### 10.3.6 Waste Storage

Central storage areas are places within the institute where different types of waste shall be brought for safe retention until it is disposal or collected for transport offsite. People who work in waste storage area shall use PPE depending on type of waste including mouth cover and eye protection whenever

The storage area shall:

- have an impermeable, hard-standing floor with good drainage (away from watercourses); the floor should be easy to clean and disinfect;
- include the facility to keep general waste separated from infectious and other hazardous waste;
- have a water supply for cleaning purposes;
- have easy access for staff in charge of handling the waste;
- be lockable to prevent access by unauthorized persons;
- have easy access for waste-collection vehicles;
- have protection from the sun;
- be inaccessible to animals, insects and birds;
- have good lighting and at least passive ventilation;
- not be situated in the proximity of fresh food stores and food preparation areas;
- have a supply of cleaning equipment, protective clothing and waste bags or containers located conveniently close to the storage area;
- have a washing basin with running tap water and soap that is readily available for the staff;
- be cleaned regularly (at least once per week);
- have spillage containment equipment;
- be appropriate to the volumes of waste generated.

### **10.3.7 Transportation of Waste**

Waste can be transported within or outside the institute for treatment or disposal. During transportation, all the necessary safety precaution shall be strictly followed to protect the handlers, public and the environment.

#### **10.3.7.1 Onsite Waste Transportation**

Onsite transport should take place during less busy times whenever possible. Set routes should be used to prevent exposure to staff, patients and pollution of the environment. Internal transport of waste should use separate floors, stairways or elevators as far as possible. Regular transport routes and collection times should be fixed and reliable. Transport staff should wear adequate PPE, gloves, strong and closed shoes, overalls and masks. Hazardous and non-hazardous waste shall always be transported separately. i. e.

1. Waste transportation trolleys for general waste should be painted black, only be used for non-hazardous waste types and labelled clearly “**General waste**” or “**Non-hazardous waste**”.
2. Infectious waste can be transported together with used sharps waste. Infectious waste should not be transported together with other hazardous waste, to prevent the possible spread of infectious agents.

Trolleys should be colored in the appropriate color code for infectious waste (yellow) and should be labelled with “**Hazardous**” or “**Infectious waste**” sign.

3. Other hazardous waste, such as chemical and pharmaceutical wastes, shall be transported separately in boxes to central storage sites.

#### **10.3.7.2 Offsite Transportation of Waste**

Transporting hazardous waste shall comply with national regulations and with international agreements if wastes are shipped across an international frontier for treatment/disposal (Secretariat of the Basel Convention, 1992). During transportation, different categories (type) of waste should be kept segregated and packed separately & properly.

Drivers of vehicles carrying hazardous waste shall have appropriate training on relevant legal regulations, waste classifications, safe handling and risks, labelling and documentation and emergency & spill cleaning procedures.

The Vehicle used for transportation shall

- be appropriate size
- have a partition between the driver’s cabin and the vehicle body, which is designed to retain the load if the vehicle is involved in a collision
- have suitable system for securing the load during transport
- have empty plastic bags, protective clothing, cleaning equipment, tools and disinfectant, together with special kits for dealing with spills, should be carried in a separate compartment in the vehicle.
- allow being steam-cleaned and internal angles should be rounded to eliminate sharp edges to permit more thorough cleaning
- have national/ international hazard sign and displayed on the vehicle and containers, as well as an emergency telephone number.
- not be used for transporting any other material. Vehicles should be kept locked at all times, except when loading and unloading,

Vehicles and transporting containers used for the transportation of waste should be cleaned and disinfected whenever waste was transported. Transport Documentation

Transport documentation (consignment note or waste tracking note) should be prepared and carried by the driver. The waste tracking note for a vehicle carrying a hazardous waste should include the following information in case of accidents or official inspection: waste classes, waste sources, pick-up date, destination,

driver name, number of containers or volume, and receipt of load received from responsible person at pick-up areas.

This information allows quick and effective countermeasures to be taken in the event of an accident or incident. On completion of a journey, the transporter should complete a waste tracking note and return it to the waste producer.

## **10.4 Treatment of Healthcare Waste**

### **10.4.1 Infectious Waste Treatment**

The choice of a facility for infectious waste treatment depends on:

- The amount of infectious waste.
- The availability of the type of facility.
- The affordability of the treatment method.
- The availability of spare parts and manpower for the maintenance of the treatment facility.
- The compatibility of the method used with the existing government regulations and standards.
- The acceptability of the method used by the society/community.

In order to dispose of infectious waste safely and to prevent the spread of infectious organisms, the waste can be treated with chemicals, heat, radiation or other methods before disposal. The following section describes different treatment methods (see chapter 11 for treatment methods).

### **10.4.2 Mechanical Treatment**

- This is a method whereby items large in size and volume, such as syringes and needles which will not be reused and body parts which need to be disposed of, are ground or shredded to reduce their volume and facilitate their decontamination using chemicals, heat or other methods.
- Necessary precautions have to be taken to prevent splashing and dispersal of the infected blood found in tissue and in needles and syringes, and the contaminated aerosol in the surrounding air, to avoid contamination of the people who operate the machine.

### **10.4.3 Chemical Disinfection**

- Choose appropriate chemicals according to their availability.
- Use the right concentration of chemicals.
- Know the correct duration of contact with the chemical.

- Grind or shred large and solid waste (see mechanical treatment above) to reduce its size and make the chemical accessible.
- Consider waste treated with chemicals as hazardous and take the necessary precautions as some strains of pathogens are resistant to chemicals.
- Before disposal, take into consideration the fact that some chemicals cannot be disposed into liquid waste pipelines.

#### **10.4.4 Heat Sterilization**

- An autoclave should be used to treat bacteriological hazardous waste before disposal.
- If available, grind or shred syringes and needles before autoclaving, to allow for easier decontamination and to prevent their reuse by scavengers.
- The size of the autoclave should be proportional to the amount of waste disposed.

#### **10.4.5 Sterilization by Microwaves**

- Use a microwave oven that is proportional to the amount of waste disposed by the laboratory.
- If available use grinding and shredding to reduce the size and volume of the waste and allow for easier treatment.
- Exposed waste to 1000C for at least 30 minutes.

#### **10.4.6 Incineration**

- If affordable, to reduce pollution of the environment with the smoke and odor, incineration has to be done at a temperature of 10000C.
- To purify the gases in the floc, a scrubber or cyclone has to be installed in the incinerator.
- Small incinerators function at low temperatures and pollute the environment with smoke and odour. Therefore, when constructing incinerators, take into consideration the height of the chimney, the wind direction and the use of combustible gases.

#### **10.4.7 Treatment of Liquid Waste**

- Disinfect with chlorine, phenol, Crysol or Lysol all liquid waste such as blood and blood products, biological culture, urine stool, mouth and nose secretions and liquid waste after cleaning floors, walls and toilets, and dispose of it in septic tanks or in the sewer line, whichever is available.

## 10.5 Special Consideration for Waste Containing Guanidine Thiocyanate

Guanidinium thiocyanate (GTC) is a chemical compound used as a general protein denaturant, being a chaotropic agent, although it is most commonly used as a nucleic acid protector in the extraction of DNA and RNA from cells. The advancement of clinical laboratory-based technology and analytical platforms for molecular testing, for instance, HIV viral load (VL) and early infant diagnosis (EID) testing have improved, and several laboratories have been providing the testing services. However, waste generated from HIV VL and EID testing contains potentially hazardous GTC. GTC is toxic to humans and can pollute waters and harm aquatic life if it is not disposed of appropriately.

In addition, it has been reported that the potential exists for the reaction of GTC liquid with bleach (sodium hypochlorite) that could elicit a toxic gas – Hydrogen Cyanide (HCN), which is highly toxic. Another potential concern when handling GTC-containing reagents is their possible reaction with acid and base solutions, since these solutions are also commonly used for the treatment of most other biological wastes. So we can't use those reagents in the case of wastes containing GTC.

It is presupposed that GTC waste disposal policies and procedures are developed with an awareness of applicable biosafety and biosecurity requirements. As with all medical waste, used vials and cartridges should be packaged in a leak-proof container for disposal. Typically, this would be as follows:

- The caps of vials and lids of cartridges are closed tightly before discarding them.
- Discarded items should be placed into a plastic, leak-proof, hazardous waste disposal bag.
- A hard-sided container should be used as the final level of containment. The cardboard box in which the shipment arrived or another cardboard box can be used for this purpose.
- Do not disinfect waste containing GTC using sodium hypochlorite or acid disinfectant.
- The sealed test cartridge and any remaining reagent vial liquid should be packaged in a leak-proof container and placed in a hard sided container. The container should then be destroyed by incineration with high temperature burning (>1000 °C).



## **10.6 Waste Disposal**

### **10.6.1 Land Fill Disposal**

In all waste systems, the removal of the remaining health-care waste materials after minimization or treatment will require access to land for final disposal. In less developed areas, where a municipality or health-care facility lacks the means to treat wastes before disposal, the direct use of a landfill is likely to be required for much of the material produced. The alternative is often an accumulation of health-care waste at medical facilities where it is openly burnt or spread indiscriminately around the facility's grounds. This constitutes a far higher risk of transmission of infection than controlled disposal in a land disposal site, even if the land disposal site is not designed to the precise standards used in higher income places

### **10.6.2 Encapsulation and Inertization**

Disposal of untreated health-care waste in municipal landfills is not advisable. However, if the health-care facility has no other option, the waste should be contained in some way before disposal. One option is encapsulation, which involves filling containers with waste, adding an immobilizing material, and sealing the containers.

# Chapter 11: Decontamination Methods

Decontamination renders an area, device, item, or material safe to handle in the context of being reasonably free from a risk of disease transmission. The primary objective of decontamination is to reduce the level of microbial contamination so that transmission of infection is prevented. The decontamination process may involve the cleaning of an instrument, device, or area with ordinary soap and water. In laboratory settings, decontamination of items, used laboratory materials, and regulated laboratory wastes is often accomplished by a sterilization procedure such as steam autoclaving, which may be the most cost-effective way to decontaminate a device or an item. The choice and use of a decontamination method, either chemical or physical, will depend on the application: decontamination of waste, surfaces, medical devices or specimens might be achieved with decontamination processes such as steam exposure or treatment with chemicals. The limitations of each method should be considered in order to select the most appropriate decontamination method.

## 11.1 Chemical Decontamination

### 11.1.1 Chemical Disinfectants and Germicides

Chemical disinfectants are categorized into three based on their efficacy of disinfection such as high level, medium level and low level. Healthcare facilities shall follow the following pre-condition upon usage of Chemical disinfectant and germicides.

- Choose appropriate disinfectants considering cost, efficacy and undesirable effects.
- Use correct concentrations following the manufacturer's recommendations for dilution.
- Do not store disinfectants in a diluted form, except for immediate use.
- Do not refill half-full diluted disinfectants. Replace the contents frequently and entirely.
- Take particular care in the use and storage of chemical disinfectants in hot regions where their shelf-life may be reduced because of high ambient temperatures.
- For personal safety, use gloves, aprons and eye protection when preparing dilutions of chemical germicides.
- Chemical germicides are generally not required for regular cleaning of floors, walls, equipment and furniture. However, their use may be appropriate in certain cases of outbreak control. Proper use of chemical germicides will contribute to workplace safety while reducing the risk from infectious agents.

### 11.1.2 Surface Decontamination

For bench tops, external surfaces and laboratory equipment's use appropriate and freshly prepared disinfectant solution.

For example

- Use 0.1% household bleach for bench top.
- Dilute the Chlorine bleach as below

Table 11: Bleach preparation

Starting NaOCl %	Ending NaOCl %	Bleach Solution Ratio	Bleach Dilution	Chlorine concentration	Shelf life
5.25%	0.53%	1:10	1 part bleach, 9 parts water	5,250 ppm	24 hours for diluted solution

- Rinse thoroughly with water any concentrated spill of sodium hypochlorite or household bleach to remove all traces as chlorine is corrosive and may damage metallic parts of any instrument.

### 11.1.3 General Disinfection

- For a spill of a potentially infectious material, use a more concentrated solution of sodium hypochlorite (e.g., 4%). But as more concentrated forms are damaging to metals, if available, use a phenolic disinfectant after diluting exactly in accordance with the manufacturer's instructions.
- Use 0.5% chlorine for decontamination of contaminated instruments unless not specified by the manufacturer of a specific instrument., test tubes, syringes and needles, gloves, etc. before disinfection, sterilization or disposal.
- The frequency with which working solutions of bleach should be changed depends on their starting strength, the type (i.e., with or without a lid) and size of the container, the frequency and nature of use, and ambient conditions.
- Change daily solutions several times a day where there is a lot of organic material. Its activity is considerably reduced by organic matter (protein). Storage of stock or working solutions of bleach in open containers, particularly at high temperatures, releases chlorine gas, thus weakening the germicidal potential.
- Change working solutions of less frequent use weekly.

Factors affecting disinfection activity include:

- Disinfectant concentration and formulation
- Contact time
- Temperature
- PH
- Relative humidity
- Inactivation by organic matter or cellulosic and synthetic materials

#### **11.1.4 Instrument Decontamination**

- For decontaminating instruments such as forceps, scissors, tongs and others, soak in 70% ethanol for one hour.
- The isopropanol is more preferable than ethanol alcohol due to its less volatility
- Other chemical disinfectants that can be used include hydrogen peroxide, phenolics or quaternary ammonium compounds, if available. However, these are irritant to the eye and skin, can be corrosive and have no sporicidal activity.

#### **11.1.5 Decontamination of Laboratory Instruments**

- Decontaminate the exterior of all equipment regularly as specified in above and according to the manufacturer's instruction, and especially before the instrument is to be serviced or repaired by a service technician.
- Decontaminate internal parts in accordance with the manufacturer's specifications. A Clearance Certificate must be issued to the service technician prior to the unit being serviced or repaired.

#### **11.1.6 Disinfectants against Spores and Mycobacteria**

Use iodine-based disinfectants for spores and mycobacteria. Some phenolics can also be used. Only phenolic disinfectants are acceptable for use in mycobacterial laboratories. Such kind of disinfectant are called high level disinfectant.

#### **11.1.7 Disinfectants against Enveloped Viruses**

Use household bleach for viruses including HIV and Hepatitis viruses which are susceptible to several disinfectants. HIV is inactivated by 10 minutes exposure to 0.5% bleach and HBV by 2 minutes exposure to the same concentration.

#### **11.1.8 Local Environmental Decontamination**

- Use a combination of liquid and gaseous disinfectants to decontaminate laboratory spaces, furniture and

equipment.

- To decontaminate laboratory spaces, furniture and equipment, use 0.1% sodium hypochlorite solution.
- In high risk situations, use 0.5% solutions. An alternative is 3% hydrogen peroxide solution
- Decontaminate rooms and equipment by fumigation using formaldehyde gas which is generated by boiling formalin. This has to be done only by specially trained and experienced personnel.
- Seal all openings with tape so that the gas cannot escape.
- Use ambient temperature and 70% humidity for fumigation.
- Ventilate the room well before allowing personnel to enter. Any person entering the room before ventilation must wear an appropriate respirator.

### **11.1.9 Decontamination of Biological Safety Cabinets**

- To decontaminate Class I and Class II Biosafety cabinets, use specialized equipment which generates formaldehyde, circulates and neutralizes it.
- Generate the formaldehyde gas by boiling formalin on a hot plate.
- Use another hot plate to vaporize 10% ammonium bicarbonate to neutralize the formaldehyde.
- In order to get 70% relative humidity, place hot water in an open container in the cabinet.
- The hot plates should be plugged in outside the cabinet.
- Seal all openings of the cabinet with a strong tape, tape a heavy gauge plastic sheet over the front opening and the sites of the entry of the electric cords of the hot plates so that no gas can come through into the room.
- First plug in the plate with formalin until all of it has vaporized. Then unplug and keep undisturbed for at least 6 hours.
- Plug in the plate with ammonium bicarbonate and allow it to vaporize.
- Then unplug the plate and switch on the cabinet blower for two intervals of 2 seconds each to allow circulation of the ammonium bicarbonate gas.
- Leave the cabinet undisturbed for 30 minutes before opening the front opening.
- Wipe the cabinet surfaces before use, to remove residues

## **11.2 Physical (Heat) Decontamination**

Heat is the most common physical method used for decontamination of pathogens. Sterilization can be achieved by physical agents such as high pressure steam (autoclaving) or dry heat and – where this

equipment is not available – by high-level disinfection.

## **11.2.1 Moist Heat Decontamination**

### **11.2.1.1 Autoclave**

An autoclave provides a physical method of disinfection and sterilization. It works with a combination of steam, pressure, and time. An autoclave operates at a high temperature and pressure in order to decontaminate certain biological waste and sterilize media. Instruments kill microorganisms and spores.

- When autoclaving is required for biohazardous waste before disposal, assure proper packing of materials.
- Put waste materials in biohazard plastic bags and any sharp objects into a rigid plastic or cardboard box before placing them in a biohazard bag (figure 14);
- Mark the bag with adhesive autoclave indicator tape, which will then show that the material has been autoclaved.
- In resource-limited settings, an autoclave must be used for sterilizing materials for reuse in the laboratory.
- When the autoclave is used for sterilizing materials for reuse in the laboratory, the materials first have to be decontaminated, cleaned and dried before sterilization.
- Decontaminate by soaking instruments in diluted bleach (0.5%); clean with soap and water and dry them before sterilization.
- Steam sterilization under pressure (autoclaving) must be used properly to be effective.
- The units of pressure marked on an autoclave's pressure gauge may vary from one autoclave to another. The following amounts of pressure (which are approximately equivalent to the above) are the desired pressure for autoclaving:
  - 106 kPa (kilopascals)
  - 1 atm (atmosphere)
  - 1 kgf/cm<sup>2</sup> (kilogram of force per square centimeter)
  - 776 torr
  - 776mm Hg (millimeter of mercury)
  - 15 pounds per square inch(PSI)
- Start measuring the time after the temperature of the material being sterilized reaches 121°C.
- As part of a preventive maintenance program, have the chamber, door seals and all gauges and controls inspected regularly by qualified personnel. Alternatively personnel training must include routine care

and maintenance of the autoclave machine.

- The steam should be saturated and free from chemicals (e.g., corrosion, inhibitors) that may contaminate the items being sterilized.
- Put all materials to be autoclaved in containers that allow ready removal of air and permit good heat penetration.
- Pack the chamber loosely so that steam will reach the load evenly. Bags should allow the steam to reach their contents.
- If the autoclave is automatic, the heat will shut off and the pressure will begin to fall once the sterilization cycle is complete.
- If the autoclave is not automatic, turn off the heat or remove the autoclave from the heat source.
- Wait to open the autoclave until the pressure gauge reads “zero.”
- When autoclaving liquids, use slow exhaust settings, as they may boil over when removed due to superheating.
- Wear suitable gloves for protection when opening the autoclave, even when the temperature has fallen.
- In any routine monitoring of autoclave performance, use biological indicators or thermocouples by placing them at the center of each load.
- Monitor regularly with thermocouples and record to determine proper operating cycles. The records must be kept in file.
- Maintain a log sheet recording the temperature, time and pressure achieved for each autoclaving cycle.
- Use chemical indicators to detect a color change after being exposed to 121°C.
- Use biological indicators once a week such as a standardized population of bacterial spores to demonstrate that the autoclave is capable of killing microorganisms.
- Use tape indicators to verify that the item to be sterilized has reached normal operating temperatures for sterilization.
- Never put sealed containers in an autoclave.

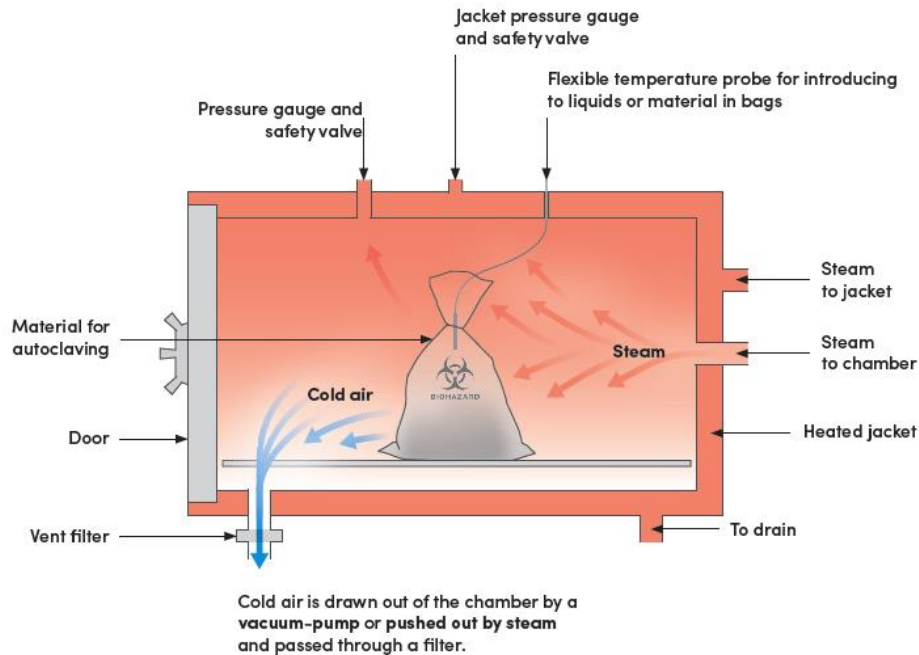

Figure 14: Components of autoclave (WHO 2020)

## 11.2.2 Dry Heat Decontamination

### 11.2.2.1 Hot Air Oven

Dry heat is a practical method of sterilization for instruments which can withstand very high temperatures (160-170°C). A simple oven can be used for dry heat sterilization as long as a thermometer is used to verify that the correct temperature has been reached. It is used to sterilize items, which do not get damaged by high temperature, such as laboratory glass, flasks, instruments with sharp cutting edges, etc.

- The benefit of dry heat includes good penetrability and non-corrosive nature which makes it applicable for sterilizing glass-wares and metal surgical instruments.
- Put the materials in metal containers or wrap them with aluminum foil to prevent recontamination after removal.
- It is also used for sterilizing non-aqueous thermo-stable liquids and thermo stable powders. Use dry heat sterilization for needles and other sharp instruments that may be blunted by steam autoclaving.
- Start timing after the desired temperature has been reached. The following temperatures and times are recommended.



Table 12: Temperatures and times recommended for autoclaving

Temperature (°C)	Time (minutes)
1700C	60 minutes
1600C	120 minutes
1500C	150 minutes
1400C	180 minutes
1210C	Overnight

### 11.2.2.2 Incineration

Incineration is a high temperature process that is usually selected to treat waste that cannot be recycled, reused or disposed of in a sanitary landfill or dump site.

- Incinerators can range from extremely sophisticated, high-temperature ones to very basic units that operate at much lower temperatures. All types of incinerators, if operated properly, eliminate microorganisms from waste and reduce by  $\pm 95\%$  the volume of the waste to ashes.
- Double-chamber, high-temperature incinerators are designed to burn infectious waste but are expensive.
- Single chamber, high-temperature incinerators are less expensive and are used when double chamber incinerators are not affordable.
- When the above two are not affordable, build simple incinerators which operate at lower temperatures from locally available materials such as brick (clay), concrete blocks or used oil or fuel drums
- Small incinerators function at low temperatures and pollute the environment with smoke and odor. Therefore, construct them with high chimneys and take the direction of the wind into consideration.
- Use combustible gases.
- Do not incinerate pressurized aerosol cans, large amounts of chemical waste, silver salts and photographic or radiographic waste, plastics containing polyvinylchloride (blood bags, IV sets, disposable syringes, etc.), and waste with high mercury or cadmium content such as broken thermometers, used batteries and lead-lined wooden panels.
- Handle ash from incinerators as hazardous waste and disposed in landfills.

## 11.3 Radiation

Radiation can be used to kill or inactivate microorganisms. Many types of radiation are used for sterilization like electromagnetic radiation (e.g. gamma rays and UV light), particulate radiation (e.g. accelerated electrons). The major target for these radiations is microbial DNA.

Two types radiation used for sterilization

A) Ionizing radiation: e.g., X-rays, gamma rays, and high speed electrons.

B) Non-ionizing radiation:, e.g. ultraviolet light, and infrared light. .

### 11.3.1 Ionizing Radiation

X-rays, gamma rays and cosmic rays are highly lethal to DNA and other vital constituents due to high penetration power. There is no appreciable increase in temperature, thus referred to as cold sterilization and has greater energy than U.V. light, therefore more effective. Used mainly in industrial facilities for sterilization of disposable items like plastics, syringes, gloves, specimen's containers, Petri Dishes, swabs, catheters, etc.

### 11.3.2 Non-Ionizing Radiation

Two types of non-ionizing radiations used for sterilization. Ultraviolet (UV) radiation is a form of non-ionizing radiation that is emitted by the sun and artificial sources, such as tanning beds. The optimum wavelength for UV sterilization is 260 nm. UV light sterilization effectively inactivates microorganisms by damaging the DNA of cells. Destroys microbial DNA, however, has limited sterilizing power because of poor penetration into most materials. Infrared is effective, however, it has no penetrating ability. It is most commonly used to purify air.

## 11.4 High-Level Disinfection (HLD)

In areas where steam sterilization by an autoclave or dry heat is not available, high-level disinfection is the only acceptable alternative. The HLD process destroys all microorganisms including vegetative bacteria, tuberculosis yeasts and viruses except some bacterial endospores, e.g., *clostridium tetani* can resist boiling for up to 90 minutes.

HLD can be achieved by:

- a) boiling in water
- b) steaming

- c) soaking instruments in chemical disinfectants

To be effective all steps in performing each method must be followed carefully.

#### **11.4.1 High-level Disinfection Using Boiling in Water**

The highest temperature boiling water will reach is 100°C at sea level. In order to high-level disinfect, the items have to be boiled for a minimum of 20 minutes. This will kill all vegetative forms of bacteria, viruses (including HBV, HCV and HIV), yeasts and fungi, but does not kill all endospores reliably. The steps to follow are:

- First decontaminate by soaking in 0.5% household bleach for 10 minutes and clean with soap and water all instruments and other items to be high-level disinfected (also see Section X, 3.2 above).
- Immerse items completely in water, if possible, and adjust the water level to be at least 2.5cm (1 inch) above the items.
- Fill all bowls and containers to be boiled with water and do not let them float with air trapped inside them.
- Close the lid and bring the water to a gentle rolling boil.
- Do not use very high heat as it wastes fuel, evaporates the water and may damage some delicate instruments.
- Start timing when the rolling boil begins and record on the HLD log.
- Do not add any items after boiling has begun.
- Boil all items for 20 minutes.
- After 20 minutes, remove objects and use them immediately or store them in high-level disinfected containers with tight-fitting covers.
- To avoid contamination, never leave items in the water after boiling has stopped.
- When the instruments are dry, if there is pooled water at the bottom, place instruments in dry high-level disinfected containers with a tight-fitting cover.
- To avoid the formation of lime deposits on the instruments, boil the water alone for 10 minutes in the morning before using it for the instruments. Then use the same water the whole day adding only small amounts of water to keep the surface 2.5 cm above the items.
- Clean and dry the pot at the end of the day.

### 11.4.2 High-Level Disinfection Using Steam

Steaming has distinct advantages over boiling because it is less destructive for plastic items such as cannulae and syringes; and it is more cost-effective because it uses much less fuel. In addition, if 1 liter of water is needed for steaming, 4 liters of water are needed for boiling. It is much more difficult to dry boiled gloves without contaminating them than steamed gloves which could be kept in the steamer pan until dry. The disadvantage of steaming is if the locally-available pots are small.

- Decontaminate all instruments and other items to be high-level disinfected and clean them with soap and water.
- Place instruments and other items in the different layers of pans with holes in their bottom as shown in Figure 14.
- After all the steamer pans have been filled, stack them one on top of the other and place them on top of a bottom pan containing water for boiling.
- Place a second empty pan without holes nearby.
- Put a cover on the top pan and boil the water to a full rolling boil. If the water doesn't boil well, the steam will not kill all organisms.
- Start timing when steam starts to come out of the cover. Record the start time on the HLD log.
- Steam items for 20 minutes.
- Then place each pan with the steamer holes on the empty pan kept nearby one by one and cover the top pan.
- Leave the items to dry.
- Use instruments immediately or store them in the pan until used or transferred into a high-level disinfected container with a tight-fitting cover.

### 11.4.3 High-Level Disinfection Using Chemical Disinfectants

There are a number of high-level chemical disinfectants available commercially.

- Select them based on the characteristics of the item to be disinfected and the skill of the personnel performing the disinfection.
- DO NOT use high-level disinfection with chemicals for needles and syringes because the residues remaining inside them are difficult to remove.
- The high-level chemical disinfectants which are available in most countries are:
  - **Chlorine solutions** are fast-acting, very effective against HIV, HBV and HCV, inexpensive,

and readily available. Their only disadvantage is that they corrode metals. High-level disinfect stainless steel metals in 0.1% chlorine solution by soaking them in a plastic instrument for 20 minutes.

- Dilute the chlorine with boiled, filtered water if the water was cloudy.
- Clean the items thoroughly and rinse and dry them before soaking.
  - **Formaldehyde (8%)** is cheap and effective, but the vapor is irritant and a potential carcinogen. Always wear protective clothing and prepare solutions in well-ventilated areas.
  - **Glutaraldehyde** is less irritating than formaldehyde. Do take the same precautions as for formaldehydes.
  - **Hydrogen peroxide (H<sub>2</sub>O<sub>2</sub>) 6%** solution is less expensive than other chemical disinfectants. The disadvantage is that it is highly corrosive and should not be used to disinfect copper, aluminum, zinc or brass. It also loses potency when exposed to heat and light. WHO does not recommend its use in hot tropical climates.

## Chapter 12: Other Laboratory Hazards

### 12.1 Chemical Hazards

Certain chemical substances used in the health facility are potentially hazardous. These hazards depend on the physical and chemical properties of the materials. Knowing how to properly move and store chemicals, as well as what to do in case of an accident, will minimize danger from exposure. Hazardous chemicals are those substances that pose a risk of damage to the body's organ such as lungs, skin, eyes, or mucous membranes and even can cause death, following short or long-term exposure.

The routes of exposure to hazardous chemicals are by inhalation, skin contact, ingestion, needle-stick, or through broken skin and mucocutaneous (eye). The different effects on the body could range from irritation of the skin and eyes, and soreness of skin to asphyxiation and death due to lack of oxygen. Some toxic chemicals can cause cancer or could be teratogenic. Corrosive chemicals can cause severe chemical burns. In order to prevent the risk of chemical hazards each facility should follow the following safety measures:

- Carry out a risk assessment to determine the potential exposure to any hazardous chemicals used in the laboratory.
- Make sure that the personnel use proper PPE during the handling of hazardous chemicals
- Make sure that the employees have training on the toxic effects of the chemicals, the routes of exposure and the hazards that may be associated with their handling and storage.
- Read material safety data sheets (MSDS) or other chemical hazard information that is available from chemical manufacturers and/or suppliers in the laboratory before using chemicals.
- Use of appropriate chemical hoods.
- Proper chemical arrangement and storage based on chemical class or category.

#### 12.1.1 Classification of Chemicals

Chemicals are classified into various hazard classifications in accordance with their physicochemical properties and health hazards. Each class of chemical has a pictorial symbol called a danger symbol. Addressing the risks posed by a chemical's classification is key to its safe use. The Hazard Classification Systems described below are using US Department of Transport system.

Table 13: Hazard classification for chemicals

Class	Chemical Hazard Classification and description
Class 1:	<b>Explosives:</b> These are chemicals or mixtures capable of producing an explosive or pyrotechnic effect with the substantial release of heat and gases under the right conditions. Explosions can be initiated by heat, shock, friction, etc
Class 2	<b>Gases:</b> Gas is a substance which at 50°C has a vapor pressure greater than 300 kPa, or is completely gaseous at 20°C at a standard pressure of 101.3 kPa. It has 3 sub classes
Class 2.1	<b>Flammable Gases:</b> Gases which ignite on contact with an ignition source, such as acetylene, hydrogen, and any material which is ignitable at 101.3 kPa (14.7 psi) when in a mixture of 13 percent or less by volume with air,
Class 2.2	<b>Poisonous Gases:</b> Gases that are neither flammable nor poisonous. Includes the cryogenic gases/liquids (temperatures of below -100°C) used for cryopreservation and rocket fuels.
Class 2.3	<b>Non-Flammable Gases:</b> Gases that are neither flammable nor poisonous. Includes the cryogenic gases/ liquids (temperatures of below -100°C) used for cryopreservation and rocket fuels
Class 3:	<b>Flammable Liquids:</b> these are defined as liquids, mixtures of liquids or liquids containing solids in solution or suspension which give off a flammable vapor (have a flash point) at temperatures of not more than 60-65°C
Class 4:	<b>Flammable solids:</b> Flammable solids are readily combustible or may contribute to fire through friction. It has 3 sub classes
Class 4.1	<b>Flammable solids:</b> Solid substances that are easily ignited. Self-reactive materials
Class 4.2	<b>Spontaneously combustible solids:</b> Solid substances that ignite spontaneously
Class 4.3	Water Reactive: it is dangerous when wet and solid substances that emit a flammable gas when wet
Class 5	<b>Organic peroxides:</b> These are substances that can readily release oxygen thus intensifying a fire. It has 2 sub classes
Class 5.1	<b>Oxidizing Agent:</b> Oxidizing agent means a material that may, generally by yielding oxygen, cause or enhance the combustion of other materials.

Class	Chemical Hazard Classification and description
Class 5.2	<b>Organic peroxides:</b> Any organic compound containing oxygen (O) in the bivalent -O-O- structure and which may be considered a derivative of hydrogen peroxide, where one or more of the hydrogen atoms have been replaced by organic radicals
Class 6:	<b>Toxic (Poison):</b> Toxic substances are those which are liable either to cause death or serious injury or to harm human health if swallowed, inhaled or by skin contact
<b>Subclass 6.1</b>	<b>Poison:</b> Toxic substances which are able to cause death or serious hazard to human health during transportation
<b>Subclass 6.2</b>	<b>Infectious substances:</b> they are substances that are known or are reasonably expected to contain pathogens. Pathogens are defined as micro-organisms (including bacteria, viruses, rickettsia, parasites, and fungi) and other agents such as prions, which can cause disease in humans or animals.
Class 7	<b>Radioactive materials:</b> Radioactive substances comprise substances or a combination of substances which emit ionizing radiation and contain radionuclides where both the activity concentration and the total activity exceeds certain pre-defined values
Class 8: Corrosives:	8: Corrosives are substances which by chemical action degrade or disintegrate other materials upon contact. These chemical agents destroy living tissue on contact
Class 9: Miscellaneous dangerous substances:	9: Miscellaneous dangerous goods are substances and articles which during transport present a danger or hazard not covered by other classes

### 12.1.2 Storage of Chemicals

Each facility should adhere the following chemical storage requirements

- Space permitting, store chemicals according to the UN Hazard Classification of Chemicals listed above.
- If space is limited, store chemicals according to their compatibility. To avoid fire and/or explosions, incompatible chemicals should not come in contact with each other.



Table 14: List of some incompatible chemicals

Substance category	Incompatible substance
Alkali metals, e.g. sodium, potassium and cesium	Carbon dioxide, hydrocarbons, water
Halogens	Ammonia, acetylene, hydrocarbons
Acetic acid, hydrogen sulfide, aniline,	Oxidizing agents, e.g. chromic acid, nitric acid,
hydrocarbons, sulfuric acid	peroxides, permanganates

- Label all chemicals with the date of receipt, the date opened and the expiration date.
- Store chemicals away from light, temperature variations and vibrations.
- Store liquids on the floor, where possible, or on the lowest shelves.
- Put corrosive liquids in shallow metal or plastic trays to contain accidental spills or breakages.
- Keep poisons and radioactive substances locked up in suitably-marked cupboards, and keep a logbook for their use.
- Store flammable liquids in flameproof lockers.
- Examine stocks of chemicals regularly to check for cracked lids, damaged containers, missing labels, and changes in the contents such as crystal formation, change of color, etc. and discard if necessary.
- Label clearly all solutions prepared in the laboratory and stored in bottles for use on the bench, clearly marked with the chemical name, its strength and the date prepared.
- Store on benches only amounts of chemicals necessary for daily use. Keep bulk stocks in specially-designated rooms or buildings.
- Always make eye wash bottles with clean water available in the laboratory.
- Make up-to-date material safety data sheets available to all staff.
- An up-to-date chemical inventory list shall be maintained
- Do not store chemicals in fume cupboards.
- Never discard any chemical by pouring it down the drain. It must be discarded in the correct manner. Follow existing regulations.

### 12.1.3 Handling of Chemicals

Each facility shall follow the following safety measure during chemical handling

- Consider all chemicals as poisonous.
- Never touch chemicals with bare hands.
- Do not pour hot solutions into reagent bottles.
- Always use funnels when pouring acids or alkalis and handle them with extreme care.
- Never pour water into any acid.
- Carry small bottles with acid with both hands.
- Transport large bottles containing dangerous chemicals in specially-designed carriers.
- Open all bottles containing concentrated acids with the use of a cloth over the stoppers and neck of the bottle (inside a fume cupboard, if available).
- Clearly mark bottles containing poisons with 'POISON' and lock them in separate cupboards and leave the key with a senior trained person.
- Label storage areas of hazardous chemicals with an appropriate warning about their hazard.
- Carry out procedures involving carcinogens, toxic gases and vapors, and boil solvents in an efficient fume cupboard.
- Never pipette by mouth. Use mechanical pipettors.
- If affordable wear personal protective equipment such as protective visors for protecting the eyes, aprons and boots. Eye protection visors should be well ventilated.
- Use gloves which are easy to remove and not tight-fitting when handling strong acids or alkalis.
- Handle known and suspected carcinogens with gloves. These substances must be labeled "CARCINOGEN-NOT TO BE HANDLED WITHOUT PROPER PRECAUTIONS." A list of such carcinogenic substances must be displayed on the bench or in the laboratory.
- Obtain MSDS (material safety data sheets, see Section XI, 7 below).
- Develop and maintain working instructions for proper storage and handling of hazardous chemicals to prevent exposure.
- Train staff (initial and annual refresher trainings, and whenever a new hazardous chemical is introduced in the lab).
- Make sure to include legal and company requirements, location and availability of MSDS, handling, emergency and spill response procedures, and waste disposal practices in the training.

## 12.1.4 Hazardous Chemicals Categorization

### 12.1.4.1 Organic Solvents

- In general, organic solvents are liquids capable of dissolving or dispersing other substances. In the laboratory, organic solvents are generally light hydrocarbons used for solubilizing lipids or extracting desired substances from a non-miscible aqueous solution. They are usually volatile and can often penetrate the skin. Work in a well-ventilated area when using solvents.

### 12.1.4.2 Corrosive Chemicals

- A corrosive chemical is a highly reactive substance that causes obvious damage to living tissue.
- Corrosives act either directly, by chemically destroying the part (oxidation), or indirectly by causing inflammation
- The major classes of corrosive chemicals are strong acids (pH < 2.1), highly alkaline bases (pH > 12.5), dehydrating agents, and oxidizing agents. Mixing should always be performed by adding the chemical to water to avoid a possibly violent reaction and subsequent spattering.
- Corrosives, if inhaled or ingested, cause severe damage to the gastrointestinal and respiratory tracts. Some substances, like sulfuric acid, penetrate deep into tissues and cause serious burns. Other corrosives may be extremely damaging to the eyes. Immediately irrigating the exposed tissue with water is critical. Continued flushing with water for a minimum of 15 minutes is essential in minimizing tissue damage. If the eyes have been affected, they must be rinsed thoroughly while the eyelids are held open.
- Store inorganic acids and alkalis including sulfuric, nitric and hydrochloric acid as well as sodium hydroxide in cool, well-ventilated places, away from incompatible chemicals or combustibles.
- Do not store acids and alkalis in the same area.
- Wash combustible materials such as woodwork, brickwork or fabric contaminated with nitric, sulphuric or perchloric acid thoroughly, or remove them to a safe location as they could explode and cause a fire on impact.
- Beware of ethers that have aged and dried to crystals, as they are extremely unstable and potentially explosive
- Wear appropriate skin and eye protection.
- Always use the weakest concentration possible.
- Use secondary containers when transporting corrosive chemicals.
- Dilute and mix slowly.

- Use appropriate label for storage see figure 15



Figure 15: Label for corrosive chemicals or materials

#### **12.1.4.3 Irritants Chemicals**

- These substances cause reversible inflammatory effects on living tissue by chemical action at the site of contact.
- Formaldehyde is both an irritant and a potential carcinogen. OSHA has issued a specific formaldehyde standard that recognizes the hazards associated with the use of formaldehyde in the laboratory.

#### **12.1.4.4 Carcinogens**

- Carcinogens are actual or potential cancer-causing agents, carcinogens are substances or mixtures of substances which induce cancer or increase its incidence. Substances and mixtures which have induced benign and malignant tumors in well-performed experimental studies on animals are considered also to be presumed or suspected human carcinogens unless there is strong evidence that the mechanism of tumor formation is not relevant for humans.
- Widely recognized carcinogens are benzene and toluene. Small amounts of the weak carcinogen alpha-naphthol (1-naphthol) are used to develop the Voges-Proskauer reaction in microbiology. Ethidium bromide, a powerful mutagen, is used to visualize DNA in molecular diagnostics.

#### **12.1.4.5 Toxins (Poisons)**

- Many chemicals are toxic or poisonous, and cause illness or death, when relatively small amounts are inhaled, swallowed, or absorbed through the skin.
- Toxic effects may be either local or systemic. Metallic mercury and its compounds are toxic.

- Check warning labels and other available information to determine if a chemical is toxic.

#### **12.1.4.6 Oxidizing Chemicals**

- Oxidizing chemicals are not themselves combustible, but can provide oxygen to accelerate their burning if stored with combustible materials.
- Do not store oxidizing chemicals and flammable liquids in the same storage area.
- Storage areas should be fire resistant, e.g. chlorates.

#### **12.1.4.7 Explosives (Reactive)**

- Explosive chemicals are reactive and unstable substances that explode easily and sustain a violent chemical change, often at normal temperatures and pressures.
- Store and handle explosives according to the MSDS.

#### **12.1.4.8 Flammable Liquid Handling and Storage**

- Flammable liquids are only stored and used in designated areas constructed and equipped with the appropriate wiring and equipment.
- Do not handle flammable liquids outside of closed systems in the presence of open flames or other ignition sources.
- Clean up spills of flammable liquids immediately and control vapor evolution from spills to prevent ignition.
- Prohibit or restrict hot work within 7.5 m of flammable liquid handling or storage areas. These areas are considered as “Hot Work High Hazard “areas.
- Keep areas of flammable liquids free from accumulated combustible waste, trash, and other combustible material within a radius of 7.5 m.
- Store small quantities of flammable liquids (e.g., solvents, laboratory reagents, etc.) in special Flammable Liquid cabinets, except the amounts needed in day-to-day operations. Total volume in a single cabinet may not exceed 227 L.
- Keep small quantities of flammable liquids requiring refrigeration in refrigerators or freezers certified to store flammable liquid.
- Use properly rated equipment for transporting flammable liquids in containers exceeding 20 liters.
- Provide overfill protection for tanks or process vessels receiving flammable liquids from bulk tanks.
- Only qualified people are permitted to handle flammable liquids.

- Keep flammable liquid containers closed while not in use.
- Move flammable liquids within the facility on trolleys or vehicles while fastened.
- Label all piping systems for flammable liquids.
- Keep an adequate supply of emergency response materials e.g., absorbent material, spill- kit, etc. at strategic points throughout the laboratory.
- Do not expose a gas feed line to a damage or leak that could cause a fire or explosion.

### **12.1.5 Radiation Hazard**

Strictly separate all work with radioisotopes from other work and designate the area clearly with prominent radiation warning signs. The facility shall prepare SOPs for using radioactive material regarding storage, work, spillage and disposal procedures and keep strict control of isotope stock in the lab.

#### **12.1.5.1 Radiation Safe Work Practices**

- Consider all radioactive material as potentially highly dangerous, and handle accordingly.
- Understand the nature of the hazard and get practical training.
- Wear appropriate PPE and dosimeters (type depends on the material handled).
- Wear disposable gloves for all procedures involving radioactive concentrations greater than 1kBq/ml, or total activity greater than 100 kBq.
- Minimize the amount of material handled. Only use what you need, put the rest away.
- Do not handle the stock vial for an extended period of time.
- Transport items in shielded secondary containers.
- Carry out all work with unsealed liquid sources in a double container or over large trays (e.g., stainless steel or plastics) lined with absorbent paper to restrict the spread of any spilled liquid.
- Perform work with concentrated solutions and strong gamma emitters only in a Radiation Room; lead shielding or lead brick walls may be necessary to protect the worker from unnecessary exposure.
- Separate items used with radioactive materials from those used with non-radioactive materials.
- Mark all radioactive preparations clearly with the radiation symbol and details of the chemical compound, radionuclide, activity, date and name of the responsible user.
- Clearly label items that are routinely contaminated such as centrifuges, water baths, tongs, sinks, etc.
- Wash and decontaminate all contaminated equipment or utensils, or dispose of them appropriately.
- Monitor the work area frequently for contamination control.

- After completion of any experimental procedure, remove all waste as specified in Section XIII, 5 below.
- Wash hands and check your hands, clothing and work surfaces with the radiation monitoring equipment for contamination after each use of radioactive material.

### **12.1.6 Material Safety Data Sheet (MSDS)**

This is an internationally-recognized document that lists specific information with regards to all chemicals as follows:

- a. Name chemical product and company identification
- b. Hazard identification
- c. First aid measures
- d. Firefighting measures
- e. Accidental release measures
- f. Handling and storage
- g. Exposure control/Personal protection
- h. Physical and chemical properties
- i. Stability and reactivity
- j. Toxicological information

### **12.1.7 Dealing with Chemical Spills**

Immediate action to be taken in case of chemical spills includes the following:

- Clear the affected area of all non-essential personnel.
- Check the presence of splash injuries on any of the personnel involved.
- Follow the procedure for chemical spills on the body as indicated on the MSDS form.
- If it is safe to do so, isolate the spill.
- Determine the level of risk based on the chemical involved and the amount spilled.
- Consult the MSDS for the particular chemical for the safety precautions to be taken and for possible reactions.
- Wear appropriate personal protective equipment.
- Do not forget the possibility of the presence of broken glass in the spilled material at any time.

In case of a spill or leak of a volatile toxic, corrosive or flammable chemical:

- personnel shall swiftly assess the situation and determine the appropriate action to resolve the situation in accordance with pre-existing, the approved local emergency plan;
- ignition sources shall be turned off if flammable materials are involved;
- barriers shall be established and warning signs posted to prevent re-entry into the spill area;
- Staff shall ensure that fume hood and other local exhausts are operating;
- eye wash facilities should be available

#### **12.1.7.1 Dealing with Chemical Spills on the Body**

- Deal with all chemical spills on any part of the body immediately. MSDS must be available for every chemical used in the laboratory.

#### **12.1.7.2 Small Skin Contamination**

- Immediately flush with water for 10-15 minutes and follow the instructions on the MSDS.
- If there is a delayed reaction, seek immediate medical attention.

#### **12.1.7.3 Chemicals in the Eyes**

- Irrigate with running water for at least 15 minutes.
- Follow MSDS for any additional treatment and seek medical help.

#### **12.1.7.4 Chemical Spills over a Large Part of the Body**

- Quickly remove all contaminated clothing using a safety shower or other source of water.
- Try not to remove clothes over the head to avoid contaminating the eyes, mouth and facial areas.
- Continue to flood the affected area with water for 15 minutes. Give additional treatment according to the MSDS and seek medical help.

#### **12.1.7.5 Ingestion of Hazardous Chemicals**

Identify the chemical ingested and take note of the treatment as directed in the MSDS.

- Rinse mouth with water.
- Do not induce vomiting unless directed to do so in the MSDS.
- Do not induce vomiting or give anything by mouth to an unconscious person. If necessary, treat for shock and seek medical attention.



#### **12.1.7.6 Inhalation of Chemicals or Gases**

- Remove the person from the affected area and provide fresh air immediately. Administer oxygen only if trained to do so.
- Seek medical help.

#### **12.1.7.7 Accidents with Poisonous Chemicals**

In laboratories where poisonous chemicals such as cyanide, etc. are used, provide a document and make special arrangements for emergency treatment according to the chemical used.

#### **12.1.7.8 Radiation Spills**

Each laboratory must prepare an SOP for accidental spillage of radioactive isotopes specific to the Laboratory or Department. The following must be available in the lab:

- Chemical/radioactive Spill Response Kit.
- A nearby safety shower.
- An eye wash station.
- A working telephone with the number of the RSO or the HSR.
- Spreading of radiation beyond the spill area can easily occur by the movement of personnel involved in the spill or clean-up effort.
- Prevent spread by confining movements of personnel until they have been monitored and found free of contamination.
- Perform remedial actions without the assistance of safety personnel only on spills resulting from the handling of small quantities of radioactivity (less than a few microcuries)
- Larger spills must be supervised by Radiation Safety Personnel.

#### **12.1.7.9 Minor Radiation Spill**

A spill is considered a minor radiation spill when there is no internal or external hazard and the spill is in a small, restricted and confined area with limited radioactivity and limited exposure.

- Notify personnel in the immediate area of the spill.
- Wearing appropriate PPE, determine the extent of the spill by observing where the liquid has splashed, and by the use of a radiation monitor.
- Confine the spill immediately by placing absorbent paper towels over the spill.
- Have all potentially contaminated personnel stay in one area until they have been monitored and

shown to be free of contamination.

- Notify the RSO or HSR.
- Attempt to clean-up only if you have received appropriate training. Follow instructions of RSO.
- Clean the area using standard cleaning agents depending on the type available in the lab, e.g., Radiac Wash.
- Dispose of all cleaning materials in a radioactive waste container.
- Monitor the area and repeat the procedure until there is no residual count at the site of the spill.
- Monitor hands and shoes for contamination with appropriate monitoring equipment.
- Report the spill to the RSO.

#### **12.1.7.10 Major Radiation Spill**

A major radiation spill is when there is an external and/or internal hazard and when a large area in a restricted area is involved or radiation escapes from the restricted area and greater than 10mCi activity is involved and spreads at a speed greater than 5mR/hr at 1 meter.

- Notify personnel in the area of the spill.
- Evacuate the area, keep hoods running and turn off oscillating fans.
- Secure and/or isolate the area to prohibit access. Stretch radiation warning tape across all access routes.
- Confine or stop source of spill with absorbent paper towels.
- Have all potentially contaminated personnel stay in one area until they have been monitored and shown to be free of contamination.
- Notify the RSO or HSR.
- Follow instructions of RSO or HSR. Do not re-enter the area until RSO or HSR gives approval.
- Have personnel who know about the incident and the laboratory remain available to provide information to emergency personnel.

## **12.2 Fire Hazard**

Fire is the combination of heat, oxygen, and fuel in the right proportions to result in a chemical reaction called oxidation. This is the most common type of emergency in laboratories. Fires can be caused by Bunsen burners, chemical spills, reactions, electrical heating units, failure of unattended or defective equipment, or overloaded electrical circuits. These fires cause the highest number of major accidents in the entire facility.

Implementation of an effective fire safety program minimizes the fire impact. The components of an effective fire safety program are as follows:

- Fire safety and evacuation plan
- Staff fire safety training plan
- Fire extinguisher training
- Train fire marshals
- firefighting equipment located at appropriate points
- Emergency exits and evacuation routes.
- Fire assembly points
- Emergency contacts

Conduct regular fire drills regularly at the minimum annually. In the event that the general alarm is sounded use the evacuation routes established for your area and follow the instructions of the Evacuation Monitors. Once outside of the building, move away from the doors to enable others to exit.

The facility shall perform following activities:

- Risk assessments have to be reviewed annually or whenever facilities, equipment or processes are added or modified which can create or change potential fire hazards, or whenever there has been a fire incident.
- Based on the (fire) safety assessment and local regulations, the lab should establish a written Emergency Response and Evacuation Plan which describes the prevention control and the response procedures in the event of fire.
- Employees who are expected to use fire extinguishers should receive an initial training and annual refresher trainings on the use of fire extinguishers.
- Training on fire extinguishers includes a “hands-on” training on real fire.
- Employees who are expected to use hose reel systems should receive initial and annual refresher training on their use.
- An adequate number of fire exits should be available in the workplace. The number depends on the number of employees and the layout of the workplace, among others. The facility should install fire alarms according to the local regulations and the fire risk assessment.
- A clear smoking policy should be established and communicated to all personnel, visitors and contractors.
- Fire extinguishers should be located according to local requirements and possible hazards.
- All fire protection systems should be inspected and maintained in accordance with local requirements

and manufacturer's instructions.

- All areas should be kept clean from flammable and combustible materials (such as loose cardboard, empty containers, etc.).
- Flammable chemicals for use in the lab and/or cleaning materials, except the amount needed in day to day operations, should be stored in special safety cabinets or equivalent.
- Buildings should be constructed and provided with fire control at a minimum level according to the local safety regulations.

### **12.2.1 Fire Hazard Management**

- Establish control systems ( install fire detection and control system)
- Conduct risk assessment related with fire hazards
- Conduct periodic inspection
- Develop and implement fire emergency systems
- Develop and implement fire incident and injury reporting systems
- Conduct periodic drill exercise on fire emergency
- Plan and deliver training for all personnel
- Proper layout of electrical circuits

The component of an effective fire safety program is as follows;

- Fire safety and evacuation plan
- Staff fire safety training plan
- Fire extinguisher training
- Train fire marshals
- firefighting equipment located at appropriate points
- Emergency exits and evacuation routes.
  - Fire assembly points
  - Emergency contacts

## **12.3 Electrical Hazards**

In the laboratory facility, workers may be exposed to electrical hazards including electric shock, arc blasts, electrocutions, fires and explosions. Electrically powered equipment, such as hot plates, stirrers, electrophoresis apparatus, lasers, heating mantles, power supplies, and microwave ovens are essential

elements of many laboratories. These devices can pose a significant hazard to laboratory workers, particularly when mishandled or not maintained. Many laboratory electrical devices have high voltage or high power requirements, carrying even more risk. In addition, Potential exposures to electrical hazards can result from faulty electrical equipment or wiring, damaged receptacles and connectors, or unsafe work practices.

The facility shall perform following activities to prevent the fire hazards:

- Electrical repairs should be left to electricians.
- All electrical wires should be treated as live. If you come across a loose or hanging wire,
  - Do not touch it! Report it to your Supervisor or Safety Representative.
- Do not use portable electrical equipment if your hands are wet or you are standing on wet ground.
- Do not use extension cords that have worn or damaged insulation.
- Always make sure that the power cord has a three-prong grounded plug, or that the equipment is double insulated.
- When disconnecting a power cord, pull on the plug not on the cord.
- Do not overload circuits by using multiple adaptors.
- ONLY CO<sub>2</sub> fire extinguishers must be used on electrical fires. DO NOT use water or foam types.
- Install circuit breakers and earth fault interrupters into all laboratory circuits. NB: Circuit breakers do not protect people. They are intended to protect electrical wiring from overheating and possibly causing fires. Earth fault interrupters are intended to protect people from electrical shocks.
- Mark all electrical distribution boards clearly and display a chart detailing which switches control what circuits (lights, plug points, geysers, etc.) on the inside.
- Use electrical distribution equipment and cordage which are suitable (consider type, size, voltage, current capacity, insulation, mechanical strength, heat generation) for the intended installation and use.
- Rate fuses, circuit breakers and other overcurrent devices correctly for the circuit they protect and do not modify them.
- Install electrical equipment in dry locations and protect it from direct contact or immersion in water unless specifically designed for such use.
- Use equipment approved for wet locations in weather-proof enclosures, and ensure that it is constructed or installed so that water cannot enter or accumulate.
- Protect motors, motor-control apparatuses, branch-circuit conductors and other equipment used in wet

areas against short-circuits or ground faults.

- Double insulate or provide with ground-fault protection controls portable electrical equipment which is likely to contact conductive liquids or is used in wet areas.
- Electrically insulate all cables/cords and cable conductors to protect them against mechanical damage.
- Join conductors by soldered or crimped joints so as not to reduce the current-carrying capacity of the cable.
- Guard electrical distribution panels against accidental damage by locating them in specifically designed rooms, using substantial guard posts and rails and by other structural means.
- Make distribution panels easily accessible and provide sufficient access, working space, ventilation and lighting.
- Mark metal-enclosed switchgear, unit substations, transformers, pull boxes, connection boxes, and other similar associated equipment with appropriate caution signs.
- Control access to electrical installations and permit entry/access only to qualified workers. Post warning signs to prevent unauthorized entry.
- Have fire control equipment approved for use on electrical fires provided by electrical power distribution centers.
- Do not use power distribution centers as storage rooms and maintain them free of flammable and combustible materials.
- Guard all live parts of electrical equipment operating at 50 volts or more against accidental contact by using approved cabinets or other forms of approved enclosures.

The facility should follow a basic safety practices for electrical tools activities

- All portable electrical equipment and workshop machines must be visually inspected for damage and wear by the user before use.
- Cover the front of each electrical panel with insulating rubber mats from which you will operate/work on the panel.
- All buildings and spaces for electrical equipment must be used strictly for their intended purpose.
- Avoid the use of double adaptors and multi-outlet power boards due to the potential for overloading and inadequate protection of circuits.
- Ensure that electrical extension leads are tested and tagged in good condition prior to use. A significant amount of heat can be generated by electrical leads which may lead to fires, especially if the current

rating for the lead is exceeded.

- When using extension leads ensure that they are fully extended, not covered by mats, or carpets and not placed where they could be a tripping hazard.
- Prior to any installation taking place, carefully consider the risk associated with electrical installations in hazardous atmospheres. Standard electrical switches, motors, lights and other equipment may act as ignition sources for solvents, paints and adhesives used in laboratories, fume cupboards, workshops or offices and must not be used in hazardous locations.
- Make sure that special circuit protection such as residual current devices (Safety Switches) or isolation transformers are available for specified electrical equipment in workshops, laboratories, construction sites and other outdoor areas.
- Select the correct earth leakage protection device to avoid an unacceptable level of circuit tripping by the devices.
- Equipment with exposed heating elements that can come into contact with combustible materials (e.g., bar radiators) must not be used. Where possible install thermostats that shut the equipment off during failure due to thermal overload.
- If electrical installations, equipment or extension leads are likely to be damaged by vehicles, other machinery or heavy people traffic, make sure they are protected by appropriate covers or barriers.
- Use caution and assume responsibility for your safety and the safety of others when working with or around electrical equipment.

## **12.4 Ergonomics**

Ergonomics is the science of fitting workplace conditions and job demands to the capabilities of the working population. Effective and successful "fits" assure high productivity, avoidance of illness and injury risks, and increased satisfaction among the workforce. Many ergonomic risk factors are present in the laboratory and/or office and include awkward posture, poorly designed workstations, excessive force, contact stresses and vibration. By learning how to prevent or control ergonomic risk factors, employee comfort, productivity and job satisfaction can be improved and the chances of occupational injuries lowered.

### **12.4.1 Responsibility**

#### **The Employer:**

Employers shall implement an effective ergonomics process that:

- provides management support
- involves employees
- identifies problems
- implements solutions
- addresses reports of injuries
- provides training
- Evaluates ergonomics efforts.
- Promote the use of proper techniques, work practices, and equipment.
- Procure ergonomically-designed furniture.
- Ensure adequate lighting.

### **Employees:**

#### General recommendations to improve Laboratory Ergonomics

- Store heavy objects on shelves below shoulder height whenever possible
- Use a stable footstool or stepladder to reach objects stored on high shelves
- Avoid twisting while carrying an object. The load should be directly in front of the worker
- Store frequently used materials on shelving units which are located between knuckle and chest height
- Utilize rotating platforms/shelves to store material close to the worker, reducing unnecessary reaching
- Increase the diameter or span of the tweezers to reduce grip force
- Use anti-fatigue mats or foot rests for areas requiring prolonged standing
- Use thin flexible gloves that fit properly
- Use tools with padded handles or large-diameter handles to reduce required grip force
- Shift weight frequently when standing for a prolonged time; use a footrest to prop up one foot at a time
- Change your position and take breaks every 20 minutes to rest muscles and increase blood flow and circulation.
- Positioned laboratory bench top devices, microscopes, and BSC equipment in line with recommendations from the manufacturer's advice for safe operations and use.
- Report early signs and symptoms of repetitive motion injuries.



### **12.4.2 Maintaining Proper Posture in the Work Place**

- Avoid using stools with little-no back support whenever possible
- Sit against the back of the chair
- Use a foot rest to ensure feet are supported
- Avoid head and neck extension whenever possible, adjust the workstation
- Use height-adjustable workstations and tables when possible
- Keep elbows close to the body and shoulders relaxed while working
- Keep frequently used trays and supplies within close reach
- If standing for long periods, use supportive shoes and cushioned mats.
- Keep your shoulders relaxed and your elbows close to your sides when working. Avoid reaching out to use instruments and work materials.
- Maintain neutral or aligned wrist and arm postures when working. Sit close to your work area, keep objects close, and adjust your chair to match the height of the bench.
- Avoid repetitive or forceful twisting and turning motions (i.e. opening valves or adjusting microscopes). Make sure valves and knobs are clean and in good working order.
- Work with your wrist in a neutral or straight position as if you were shaking hands with someone.
- Use light pressure when performing tasks such as pipetting.
- Use electronic pipettes or light touch models whenever possible.
- Select equipment and tools that are the right size for your hand.
- Use padding and tubing to reduce pressure and force when working. For example, use rubber tubing on forceps to increase diameter and reduce pinch force. Soften sharp edges on work surfaces with padding.
- Use thin, flexible gloves that fit properly. Unfitting and poorly designed gloves increase pinch and grip forces when working.

### **12.4.3 Poorly Design Work Station**

- You should avoid a repetitive action exceeds the body's capacity to cope with the action.
- Design work stations, equipment, machineries and tools that matched to the the workers
- Use adjustable working tables and benches.

- Organization of the workspace is another important aspect. Provide enough room to move around and to change your body position. Providing built-in foot rails or portable footrests allows the worker to shift their body weight from one leg to the other.
- Provide elbow supports for precision work to reduce tension in the upper arms and neck.
- Where possible, provide a seat so that the worker can do the job either sitting or standing.
- Change body positions frequently so that working in one position is of a reasonably short duration to improve blood supply to the working muscles (standing/sitting). Both sitting and changing positions contribute to the reduction of overall fatigue.
- Quality of footwear and type of flooring materials are also major factors contributing to standing comfort.
- Avoid extreme bending, stretching and twisting. Pace the work appropriately and allow suitable rest periods to relax. Different exercises may also help.
- Provide instruction on proper work practices and the use of rest breaks.
- The worker should be aware that rest periods are important elements of the work and should be used to relax when muscles are tired, to move around when muscles are stiff, to walk when work restricts the worker's ability to change postures or positions, and so on.
- Avoid reaching above or behind the shoulder line. Shifting your feet to face the object is recommended. Also, avoid overreaching beyond the point of comfort.
- Keep work areas clean at all times.
- Avoid standing on concrete or metal floors. Those recommended for standing work are wooden, corks or rubber covered floors.
- Ensure that the floors are level and non-slippery.
- Cover concrete or metal floors with mats. Slanted edges on mats help prevent tripping.

#### **12.4.4 Job Design**

A job design suitable for the worker, and the tasks plus good job design, are important for workers who work in a sitting position. A workstation shall allow the worker to sit in a balanced body position.

- Use a workstation that ensures that the alignment of the spine is the same whether the worker sits or stands.
- Use a workstation that allows the worker to move the spine freely.
- The number of people and equipment in each room should be limited to allow for free movement.

- Design tasks so they require movement of the spine and encourage the worker to alternate positions frequently.
- Avoid an excessive range of movement by providing and positioning all materials at working level and within easy reach.
- Avoid lifting and transferring loads while sitting.
- Position visual tasks

## Chapter 13: Emergency Preparedness and Response

An emergency is a sudden/ an unexpected event when the laboratory operation loses control, or could lose control, of a situation that may result in risks to human health, property, or the environment, either within the facility or in the local community.

### 13.1 Emergency Preparedness

Emergency situations are bound to occur in work places, and laboratories are not an exception. To minimize the impact of these situations each facility shall develop an emergency preparedness and response plan. Therefore, the facility emergency preparedness and response plan shall be commensurate with the risks of the facility, and the plan shall contain the following basic components: Administration (policy, purpose, distribution, definitions, etc)

- Organization of emergency areas (command centers, medical stations, Assembly area, emergency exits etc)
- Roles and responsibilities
- Develop and implement Laboratory emergency preparedness plan
- Coordination and collaboration mechanism with concerned bodies
- Communication systems
- Emergency response procedures
- Emergency resources
- Training and updating
- Checklists (role and action list and equipment checklist)
- Business Continuity and Contingency

In addition, Laboratory Emergency Preparedness and Response Plan, incorporated into and consistent with, the facility's overall Occupational Health and Safety and Employment Standards (OHS) shall be prepared to cover the following:

- Planning Coordination: Procedures shall be prepared for:
  - Emergencies Identification.
  - Informing the public and emergency response agencies
  - Documenting first aids and emergency medical treatment

- Taking emergency response actions
- Reviewing and updating the emergency response plan to reflect changes, and ensuring that employees are informed of such changes
- Emergency Equipment: Procedures shall be prepared for using, inspecting, testing, and maintaining the emergency response equipment.
- Training: Employees shall be trained on emergency response procedures.
- Include emergency response training details in the comprehensive site work plan.
- Ensure that personal protective equipment (PPE) and other equipment for emergency response in the emergency response plan are identified.
- Site-specific emergency response procedures and contact address would be shared to relevant personnel
- Regularly rehearse and training would be provided to employees as part of the overall training program for site operations.

### **13.1.1 Emergency Services Contact**

The telephone numbers and addresses of the following should be prominently displayed in the facility:

- |   |  |
|---|--|
| • Director of the institution or laboratory | • Hospitals/ambulance services/medical staff |
| • Laboratory supervisor                     | • Police                                     |
| • Safety officer                            | • Responsible technician                     |
| • Fire Services                             | • Water and electricity services authority.  |

## **13.2 Emergency Equipment**

The following emergency equipment must be available:

- First-aid kit, including universal and special antidotes
- Appropriate fire extinguishers, fire blankets

In addition the following are also available according to local circumstances:

- Full protective clothing (one-piece coveralls, gloves and head covering – for incidents involving microorganisms in Risk Groups 3 and 4)
- Full-face respirators with appropriate chemical and particulate filter canisters
- Room disinfection apparatus, e.g. sprays and formaldehyde vaporizers
- Stretcher
- Tools, e.g. hammers, axes, spanners, screwdrivers, ladders, ropes

- Hazard area demarcation equipment and notices.

### 13.2.1 Emergency Evacuations

Each facility ensures that an action plan for emergency evacuation shall be developed and , the plan shall take into consideration; chemical, microbiological, fire, and other possible emergencies. This shall include measures to be taken to leave the unoccupied building in as safe a state as possible. All personnel, including visitors, shall be made aware of the action plan, routes of exit, and assembly points for emergency evacuation.

### 13.2.2 Facility Utilities Information

Each facility shall have an information about building and site maps that indicate:

- Utility shutoffs
- Water hydrants
- Water lines and main valves
- Gas lines and main valves
- Electrical cutoffs
- Electrical substations
- Sewer lines
- Location of each building (include name of building and number)
- Floor plans
- Alarm and enunciators
- Fire extinguishers
- Fire suppression systems
- Exits
- Stairways
- Designated escape routes
- Restricted areas
- Hazardous materials (including cleaning supplies and chemicals)
- High-value items

**Resource lists:** lists of major resources (equipment, supplies, and services) that could be needed in an emergency; mutual aid agreements with other companies and government agencies.

In an emergency, all personnel should know:

- What is my role and where should I go?

Facilities are required to develop:

- Emergency escape procedures and routes
- Procedures for employees who perform or shut down critical operations before an evacuation
- Procedures to account for all employees, visitors and contractors after an evacuation is completed
- Rescue and medical duties for assigned employees
- Procedures for reporting emergencies
- Names of persons or departments to be contacted for information regarding the plan
- Emergency plan review

The plan shall be reviewed annually and after every “EVENT”.

While carrying out the review ask the following questions:

- a) What went as planned?
- b) Where did the plan go wrong?
- c) Why did it go wrong?
- d) What can be improved?
- e) Where is training lacking?

## **13.3 Emergency Response**

### **13.2.1 Emergency Response Procedure**

- The procedures spell out how the facility will respond to emergencies. Whenever possible, develop them as a series of checklists that can be quickly accessed by senior management, department heads, response personnel and employees. Each facility shall develop its own checklist which determine what action should be necessary to assess the situation
- Protect employees, customers, visitors, equipment, vital records and other assets, particularly during the first three days
- Get the facility back up and running.

Specific procedures might be needed for any number of situations such as bomb threats or floods, and for such functions as:

- Warning employees and customers
- Communicating with personnel and external responders e.g. police, fire brigade, ambulance
- Conducting an evacuation and accounting for all persons in the facility
- Managing response activities
- Activating and operating an emergency operations center
- Fighting fires
- Shutting down operations
- Protecting vital records
- Restoring operations

## **13.4 Emergency Preparedness and Response Training**

After the preparation of the plan all staff shall be trained as part of the implementation and thereafter staff shall be trained periodically as institution requirement, preferably annually. The training shall cover:

- Emergency response plan
- Emergency drill

## Reference

- Biorisk management. Laboratory biosafety Guidance. Geneva: World Health Organization; 2006 ([https://www.who.int/csr/resources/publications/biosafety/WHO\\_CDS\\_EPR\\_2006\\_6.pdf](https://www.who.int/csr/resources/publications/biosafety/WHO_CDS_EPR_2006_6.pdf)),
- Biosafety in microbiological and biomedical laboratories, 5th edition. Washington, DC: US Department of Health and Human Services; 2009
- Burnett LC. Developing a biorisk management program to support biorisk management culture. In: Wooley DP, Byers KB, editors. Biological Safety: Principles and Practices. 5th ed. Washington (DC): ASM Press; 2017. p. 495-510.
- Casadevall A, Pirofski L. The weapon potential of a microbe. Trends in Microbiology. 2004;12(6):259-63.
- Caskey S, Sevilla-Reyes EE. Risk Assessment. In: Laboratory Biorisk Management: Biosafety and Biosecurity. Salerno RM, Gaudioso, J, editors. Boca Raton: CRC Press; 2015. p. 45-63.
- CDC. Interim Infection Prevention and Control Recommendations for Patients with Suspected or Confirmed Coronavirus Disease 2019 (COVID-19) in Healthcare Settings. Updated April 14, 2020. CDC Accessed on April 22, 2021 at: [https://www.cdc.gov/coronavirus/2019-ncov/hcp/infection-control-recommendations.html?CDC\\_AA\\_refVal=https%3A%2F%2Fwww.cdc.gov%2Fcoronavirus%2F2019-ncov%2Finfection-control%2Fcontrol-recommendations.html](https://www.cdc.gov/coronavirus/2019-ncov/hcp/infection-control-recommendations.html?CDC_AA_refVal=https%3A%2F%2Fwww.cdc.gov%2Fcoronavirus%2F2019-ncov%2Finfection-control%2Fcontrol-recommendations.html)
- Centers for Disease Control and Prevention (CDC). Interim Infection Prevention and Control Recommendations for Patients with Suspected or Confirmed Coronavirus Disease 2019 (COVID-19) in Healthcare Settings. Update April 13, 2020. Accessed on April 14,
- NRC. Responsible Research with Biological Select Agents and Toxins. Washington, DC: National Academies Press; 2009
- Centers for Disease Control and Prevention (CDC) National Institutes of Health. Biosafety in microbiological and biomedical laboratories. CDC 2020.
- Centers for Disease Control and Prevention [Internet]. Atlanta (GA): The National Institute for Occupational Safety and Health (NIOSH); c2015
- CLSI. Protection of Laboratory Workers from Occupationally Acquired Infections: Approved Guideline—Fourth Edition. CLSI document M29-A4. Wayne (PA): Clinical and Laboratory Standards Institute; 2014.
- Decontamination and waste management. Geneva: World Health Organization; 2020 (Laboratory biosafety manual, fourth edition and associated monographs).
- Guidance on regulations for the transport of infectious substances 2019-2020. Geneva: World Health Organization; 2019 (WHO/WHE/CPI/2019.20) (<https://apps.who.int/iris/bitstream/handle/10665/325884/WHO-WHE-CPI-2019.20-eng.pdf?ua>).
- Health and Safety Guidelines for Public Health Laboratories in Ethiopia. Ethiopian Health and Nutrition Research Institute Federal Ministry of Health Addis Ababa, Ethiopia: 2010
- Health Care Waste Management Manual for Ethiopia, Ministry of Health, Addis Ababa, Ethiopia; 2021



- Infectious substances shipping guidelines, 15th edition (2019/2020). Montreal, International Air Transport Association; 2019
- International Organization for Standardization (ISO) 15190:2020, Medical laboratories – Requirements for safety, 2<sup>nd</sup> edition; 2020.
- International Organization for Standardization (ISO) Biorisk management for laboratories and other related organisations, 1<sup>st</sup> edition: 2019,
- Kojima K, Bennett A, Blacksell S, Heisz M, Makison Booth C, McKinney M, Summermatter K. Laboratory biosafety manual. 4<sup>th</sup> Edition. World Health Organization. 2020.
- Laboratory design and maintenance. Geneva: World Health Organization; 2020 (Laboratory biosafety manual, fourth edition and associated monographs).
- Laboratory safety guidance. Washington, DC: Occupational Safety and Health Administration, US Department of Labor; 2011 (<https://www.osha.gov/Publications/laboratory/OSHA3404laboratory-safety-guidance.pdf>),
- Schell WA. Mycotic Agents. In: Wooley DP, Byers KB, editors. Biological Safety: Principles and Practices. 5th ed. Washington (DC): ASM Press; 2017. p. 147–62.
- The International Federation of Biosafety Associations Laboratory biosafety and biosecurity risk assessment technical guidance document. Albuquerque: Sandia National Laboratories; 2014 (<https://prod-ng.sandia.gov/techlib-noauth/access-control.cgi/2014/1415939r.pdf>).
- United Nations. Recommendations on the transport of dangerous goods: model regulations, 21st revised edition. New York, Geneva: United Nations; 2019
- WHO guidance on implementing regulatory requirements for biosafety and biosecurity in biomedical laboratories – a stepwise approach. Geneva: World Health Organization; 2020 (<https://apps.who.int/iris/bitstream/handle/10665/332244/9789241516266-eng.pdf?sequence=1&isAllowed=y>)
- WHO. Rational use of personal protective equipment for coronavirus disease (COVID-19): Interim guidance. 19 March 2020. WHO Geneva. 2020 Accessed on April 2, 2020 at, <https://www.cdc.gov/coronavirus/2019-ncov/hcp/infection-control-recommendations.html>
- WHO. Water, sanitation, hygiene, and waste management for the COVID-19 virus: interim guidance. Interim guidance. 19 March 2020. WHO Geneva. 2020
- World Health Organization (WHO). Maintaining infection prevention and control measures for COVID-19 in health care facilities. Policy brief. WHO July 7, 2022.
- Wooley DP, Fleming DO. Risk assessment of biological hazards. In: Wooley DP, Byers KB, editors. Biological Safety: Principles and Practices. 5th ed. Washington (DC): ASM Press; 2017. p. 95–104.
- World Health Organization. Laboratory biosafety manual. Third edition. Geneva: World Health Organization; 2004.
- World Health Organization. Laboratory biosafety manual. Fourth edition. Geneva: World Health Organization; 2004.

## Annexes

### A. Annex 1: Biosafety and Biosecurity Audit Checklist

Facility Name	
Name of Auditor/s	
Lab Representative	
Date of Inspection	

#### Instruction

This **Audit Checklist** contains 12 sections with a total of 63 questions and uses to audit/ inspect Bio safety practices. Responses to all questions must be, “Yes”, "Partial", “No” or "Not Applicable ".

For each activity that conforms to the requirement place a “**Yes (Y)**” mark in the column. If any activity of the requirement is fulfilled partially place a “**Partial (P)**” mark in the column and If no requirement is fulfilled, place a “**No (N)**” mark in the column as well as if the question is not relevant or not applicable place a mark “**Not Applicable (NA)**” mark in the column. When marking “Partial” or “No”, notes should be written in the comments field to explain why the laboratory did not fulfill this item to assist the laboratory with addressing these areas of identified need following the audit. Inspectors complete this inspection using the methods below to evaluate laboratory operations per checklist items and to document findings in detail.

- **Review records/documents** to verify that the laboratory safety manual, policies, safety audit, incident reports, Standard Operating Procedures (SOPs) and other related manuals are complete, current, accurate, and annually reviewed.
- **Observe laboratory safety practice** to ensure:
  - laboratory follows written safety policies and procedures in pre-analytic, analytic and post-analytic phases of laboratory testing;
  - Staff safety practice and
  - Nonconformities identified are adequately investigated and resolved.
- **Ask open-ended questions** to clarify documentation seen and observations made.

**Note:** In the checklist under column section “what look” will be guide you what to look during the audit

S.N	Requirements	Status/P/N/NA	Comments
<b>1.</b>	<b>Section 1: Safety Officer, Safety Manual,</b>		
1.1	Is there an appointed Biosafety Officer (BSO)?		
1.2	Has the Biosafety Officer been trained to perform their duties?		
1.3	Is there an institutional biosafety plan?		
1.4	Is a safety manual specific for the laboratory's needs readily available to all employees?		
1.5	Is there evidence that employees have read the manual?		
1.6	Are there instructions regarding job hazards that describe how to carry out tasks safely and what to do if an incident occurs?		
1.7	Are other essential safety-related procedures, policies (aside from the safety manual) available in the laboratory?		
<b>2.</b>	<b>Section 2: Safety Program</b>		
2.1	Is the safety program reviewed annually?		
2.2	Is there a plan for emergency evacuation?		
2.3	Is there a complete fire safety plan?		
<b>3.</b>	<b>Section 3: Risk Assessment</b>		
3.1	Do staff have a knowledge on risk assessment or management?		
3.2	Is there a written policy and/or a standard operating procedure (SOP) for performing risk assessments?		
3.3	Do risk assessments consider both agent hazards and laboratory procedure hazards?		
3.4	Has the person performing the risk assessment received training and are they experienced in risk assessments?		
3.5	Is a risk assessment performed (tick each) when: 3.5.1 New assays are introduced 3.5.2 New methods are introduced 3.5.3 Equipment is moved 3.5.4 New equipment is introduced? 3.5.5 The potential for aerosolization is introduced 3.5.6 The potential for needlesticks is introduced? 3.5.7 A laboratory is physically moved? 3.5.8 A new pathogen is detected? 3.5.9 Staffing changes? 3.5.10 Other specify_____		
3.6	Are risk assessments conducted annually for assays performed in the laboratory?		
3.7	Is there documented risk assessment report available.		
3.8	Is there a procedure specifying how identified risks will be mitigate?		
3.9	Are actions plan developed and implemented for those identified risks during the risk assessment?		
3.10	Are hazardous areas and the presence of certain hazards (e.g., flammable) identified?		
3.11	Are visitors, non-permanent staff and other workers made aware of hazards in the laboratory?		
3.12	Has the laboratory performed a risk assessment to determine which procedures require the use of a biological safety cabinet?		
<b>4.</b>	<b>Section 4: Safety signage</b>		
4.1	Is a lab hazard caution sign posted and current?		
4.2	Are additional hazard warning signs (laser, magnetic fields, high voltage, etc.) posted in lab near the hazard?		

4.3	Is a laboratory floor plan, as described in the lab safety manual, posted?		
<b>5.</b>	<b>Section 5: Reporting of Incidents,</b>		
5.1	Is there a program for reporting safety-related accidents/incidents?		
5.2	Are detailed reports filed for all incidents/accidents?		
5.3	Are the accident/incident reports reviewed by laboratory management to ensure that remedial action(s) is taken to avoid recurrence?		
5.4	Is there a procedure and process (e.g., vaccination where applicable) regarding occupational exposure to Human Immunodeficiency Virus, Hepatitis B Virus, Hepatitis C Virus and tuberculosis?		
5.5	Is there regular medical checkup for laboratory associated infection and records of identified case presenting for annual management review?		
5.6	Are emergency contact numbers, including after-hours emergency contact numbers for lab staff, posted within the laboratory?		
<b>6.</b>	<b>Section 6: Safety Orientation and Training</b>		
6.1	Is there evidence that a safety training program is in place?		
6.2	Is there evidence that all staff have been trained in the safe handling, use and disposal of sharp instruments and devices?		
6.3	Has lab specific training been completed and documented?		
6.4	Is there evidence that staff are trained to be aware of the hazards associated with the handling of body fluids?		
6.5	Are lab employees trained to ensure that all applicable regulations are followed when transporting for transport biological material and dangerous goods?		
<b>7.</b>	<b>Section 7: Personnel Responsibilities and Safe Work Practices</b>		
7.1	Is there evidence that work areas are inspected annually for safety?		
7.2	Do staff consistently practice standard precautions to ensure the protection of themselves, co-workers, patients, and the public from exposure to sources of danger?		
7.3	Are all samples, control materials, biologically sourced calibrators, cultures and waste assumed to contain viable pathogens and handled in a safe manner?		
7.4	Are food and drink prohibited in the laboratory where specimens are stored and handled and from specimen/reagent refrigerators?		
7.5	Is smoking prohibited in the laboratory?		
7.6	Is there evidence that the application of cosmetics and the handling of contact lenses are prohibited in the laboratory?		
7.7	Is personal property stored where it cannot become contaminated?		
7.8	Are workers and visitors required to wash their hands immediately after contact with infectious substances, patients or when leaving the lab?		
7.9	Are dedicated hand-washing sinks available and located in areas where biological materials are handled or close to exits?		
7.10	Is there evidence that mouth pipetting is prohibited?		
7.11	Has the laboratory management determined and implemented a procedure for handling sharps, including use of puncture-resistant containers?		
7.12	Are samples centrifuged safely?		
7.13	Was a safety inspection performed and documented within the last 12 months?		
7.14	Are eyewashes and showers accessible		
7.15	Are eyewashes and showers free of obstructions?		
7.16	Are eyewashes and showers flushed on a weekly basis and is the flushing documented?		
7.17	Is there continuous water supply source in the laboratory		
<b>8.</b>	<b>Section 8: Personal Protective Equipment (PPE)</b>		
	Is PPE provided to staff, visitors, and patients as required?		
	Are supplies of minimum PPE required for routine work available to all lab members?		

3	Is basic PPE provided for all personnel working in the laboratory? (basic PPE includes gloves, laboratory coats or gowns, protective eyewear or face protection, etc		
4	Has the laboratory management determined and implemented the criteria for the transport and washing of contaminated clothing?		
5	Has the laboratory management provided appropriate gloves for those staff that suffer from allergies or reactions?		
5	Is there a written procedure for appropriate donning and doffing PPE including laboratory coats, gloves, protective eyewear, face shields, N95 and/or PAPRs?		
7	Is there evidence that shoes with open toes are prohibited in the laboratory?		
<b>9.</b>	<b>Section 9: Emergency kit availability and Practices</b>		
9.1	Are chemical & Biological spill kits available?		
9.2	Does the laboratory have access to chemical/biological spill kits?		
9.3	Do lab staffs have access to a fully stocked first-aid kit?		
9.4	Are appropriately trained personnel and appropriate equipment available to provide first aid, if required?		
9.5	Is there a process defined for the disposal of chemicals?		
<b>10.</b>	<b>Section 10: Good Housekeeping</b>		
10.1	Is the lab free of slip and trip hazards?		
10.2	Is there minimal glassware stored in the sink or on the bench top?		
10.3	Are laboratory work areas tidy and uncluttered, exits, aisles and corridors unobstructed?		
10.4	Are there exit signs and adequate lighting at the point of exit from the laboratory?		
10.5	Is there documented evidence that work surfaces and equipment are cleaned and disinfected when required (whenever spills or contaminations occur) and laboratory benches disinfected at the end of each shift?		
10.6	Are lab coats regularly laundered by MediCleanse or similar industrial laundry service?		
10.7	Is a person designated to oversee good housekeeping practices?		
10.8	Are processes that emit vapors, gasses, or fumes adequately captured by local ventilation room (Window, air sac)?		
<b>11.</b>	<b>Section 11: Biological Hazard</b>		
11.1	If the lab works with biohazards involving recombinant DNA, human or non-human primate material, or pathogenic agents, does it have a responsible person and stored or handle with a lockable refrigerator?		
11.2	Are biosafety drills and exercises performed at predetermined intervals?		
11.3	Does the type of the biological agent identified and the biosafety level of the laboratory matched?		
11.4	Does the laboratory perform biological agent inventory regularly?		
11.5	Does the laboratory have a license to handle the agent that classified as National dangerous biological agent?		
<b>12.</b>	<b>Laboratory equipment</b>		
12.1	Is BSC installed so that fluctuations of the room air supply and exhaust do not interfere with proper operations?		
12.2	Is BSC located away from doors, heavily traveled laboratory areas, and other possible airflow disruptions?		
12.3	Have biological safety cabinets been certified by a qualified person before being placed into service, when HEPA filters are changed, when moved or after maintenance, and at least annually to ensure that they function as designed?		

12.4	Does the laboratory employ an appropriate containment level for their operational practice and are staff familiar with required operational guidelines?		
12.5	Are all hazardous pieces of machinery mounted or secured to prevent movement or tipping?		
12.6	Are all points of operation, rotating components, and other moving parts of machinery properly guarded to prevent injury?		
12.7	Is laboratory equipment with potential hazards routinely inspected, and maintained or serviced as recommended?		
<b>13.</b>	<b>Section 13: Chemical Safety</b>		
13.1	Has the lab's chemical inventory been reviewed and updated within the last year?		
13.2	Are all containers clearly labelled with their contents and primary hazard(s)?		
13.3	Can all lab staff readily access an MSDS/SDS via softcopy or hardcopy in the lab?		
13.4	Are hazardous liquids and gas cylinders appropriately stored?		
13.5	Are containers for flammable liquids as small as possible, appropriately stored and closed when not in use and are they transported in safety containers?		
13.6	Is there a process defined for the disposal of chemicals?		
13.7	Are fume hoods available at chemical or reagent preparation area?		
13.8	Are flammable liquids stored outside of flammable liquid storage cabinets, and are they stored in approved safety container?		
13.9	Are all chemical containers intended for chemical use in good condition (not corroded or leaking)?		
13.10	Are all chemical containers closed?		
13.11	Are incompatible chemicals segregated when they are being stored?		
13.12	Are hazardous materials storage cabinets appropriate for their contents, properly labeled and in good condition?		
13.13	Are chemical containers being stored away from sinks?		
13.14	Are corrosive chemicals stored below eye level?		
13.15	Is the lab free of chemicals that are old and no longer needed?		
13.16	Are gas cylinder valve protection caps in place for gas cylinders not in active use?		
13.17	Are compressed gas cylinders secured to prevent them from falling or tipping?		
<b>14.</b>	<b>Section 14: Electrical safety</b>		
14.1	Are building electrical panels accessible?		
14.2	Is there evidence that power cords and plugs are regularly inspected for damage and fraying?		
14.3	Are containers for flammable liquids as small as possible, appropriately stored and closed when not in use and are they transported in safety containers?		
14.4	Are extension cords or power strips daisy-chained to each other?		
14.5	Are extension cords used only as temporary wiring and not running under carpets, doors, or through walls and ceilings?		
14.6	Is equipment with motors, heaters, and other high amperage needs plugged directly into a wall receptacle?		
14.7	Are ground fault circuit interrupters (GFCI's--either fixed GFCI receptacles/breakers or using adaptors) employed in wet locations?		
<b>15.</b>	<b>Section 15, Fire Safety</b>		
15.1	Are portable fire extinguishers visible and accessible, and do they have the correct rating for the hazards present?		
15.2	Are there 18 inches of clearance between stored items and fire sprinklers?		
15.3	Is there evidence that all personnel participate in an annual fire drill or other emergency evacuation training?		
15.4	Are areas well-ventilated where flammable gases and liquids are used?		
15.5	Are areas well-ventilated where flammable gases and liquids are used?		
15.6	Are flammable gases and liquids kept away from sources of heat or ignition including electric motors and direct sunlight?		
<b>16.</b>	<b>Section 17: Waste Disposal</b>		

16.1	Are staff familiar with the requirements for the handling and disposal of hazardous waste?		
16.2	Is waste disposed of on a regular basis and not allowed to accumulate?		
16.3	Are potentially infectious materials placed in a durable, leak proof container during collection, handling, processing, storage, or transport within a facility?		
16.4	Are laboratory equipment routinely decontaminated, as well as, after spills, splashes, or other potential contamination?		
16.5	Are spills involving infectious materials contained, decontaminated, and cleaned up by staff properly trained and equipped to work with infectious material?		
16.6	Are equipment decontaminated before repair, maintenance, or removal from the laboratory?		
16.7	Are chemical waste containers in good condition and compatible with their contents?		
16.8	Are chemical waste containers closed?		
16.9	Are incompatible chemical wastes segregated by hazard class?		
16.10	Are all chemical waste containers labelled with a completed hazardous waste label?		
16.11	Is lab glass placed in sturdy (durable) cardboard boxes that are labelled with the room number and focal personnel name?		
16.12	Are liquid waste decontaminated before disposal through sink?		
16.13	Are liquid waste sink available in the laboratory?		
16.14	Does incinerator available with in the laboratory facility? If not, how do the dry waste are disposed and decontaminated?		
<b>17.</b>	<b>Section 18: Safety Audits, and Monitoring</b>		
17.1	Are internal safety audits performed at least annually and after significant safety breaches?		
17.2	Are there procedures in place to detect safety breaches when they occur?		
17.3	Is there a system to report safety breaches to laboratory leadership?		
17.4	Is there a procedure specifying how biosafety breaches will be addressed and which staff are responsible for addressing them?		
17.5	Is there a system in place for performing root cause analysis of safety breaches?		
17.6	Are corrective actions implemented when breaches in biosafety are identified?		
<b>18.</b>	<b>Section 19 Summary and Recommendations</b>		
18.1	Summary		
18.2	Recommendations		

## **B. Annex 2: General Procedures for Spill Cleanup**

1. Determine the nature and the extent of the spill—what has been spilled (i.e., the chemical or biological agent), its concentration, quantity, and location.
2. Evacuate the area immediately (if necessary to prevent exposure of additional persons to a particularly toxic or virulent agent).
3. Provide immediate medical treatment to those exposed (if warranted by the nature of the exposure).
4. Secure and post the spill area to prevent additional exposures and spread of the spill.
5. Put on appropriate personal protective equipment (PPE).
  - a. Always: glasses, gloves, lab coat or apron, shoe coverings.
  - b. As appropriate (depending on the nature of the spill): face shield or goggles, respirator, boots.
6. Contain the spill (e.g., by dyking or ringing with absorbent material).
7. Decontaminate the spilled material if warranted (i.e., it is often prudent to decontaminate the spilled material before it is picked up). Disinfect using 10% bleach solution or another approved disinfectant (see section 10.6) for a thirty-minute contact time.
8. Pick up the spilled material:
  - A. Solids:
    - Pick up by mechanical means (e.g., pan and brush, forceps).
    - Discard as medical, hazardous, or radioactive waste as appropriate.
  - B. Liquids:
    - Absorb the spill with absorbent material as appropriate (e.g., paper towels, vermiculite).
    - Discard as medical, hazardous, or radioactive waste as appropriate.
  - C. Broken glass and other sharps:
    - Pick up by mechanical means (e.g., forceps, pan and brush), never by hand.
    - Dispose as sharps.
9. Decontaminate the area using an appropriate disinfectant (see Section 10.6).
10. Rinse/clean the area (if necessary) and absorb and collect waste materials.
11. Dispose of collected material and cleanup materials as medical, hazardous as appropriate.
12. Decontaminate reusable items (such as dust pans, brushes, and forceps).
13. Remove personal protective equipment (PPE).
  - a. Discard disposable items as medical, hazardous, or radioactive waste as appropriate.
  - b. Decontaminate reusable items (such as heavy rubber gloves, boots, aprons, gowns) before cleaning or laundering.
14. Wash all exposed skin thoroughly.
15. Perform medical treatment and follow up as appropriate for the particular type of material.



## C. Annex 3: PPE Donning and Doffing Procedures

### 1. Sequencing for Donning Personnel Protective Equipment (PPE)

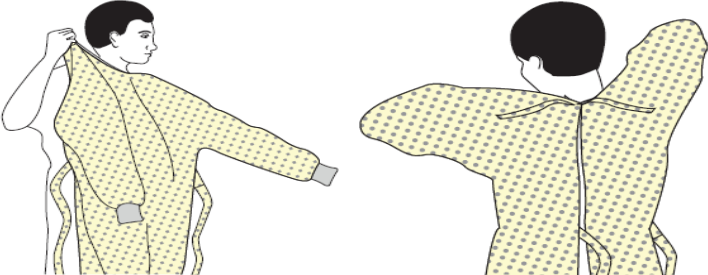
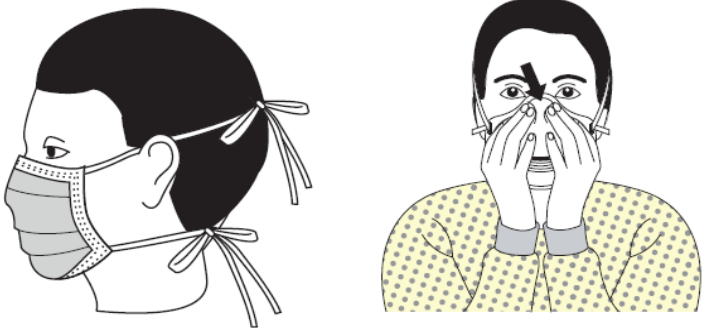
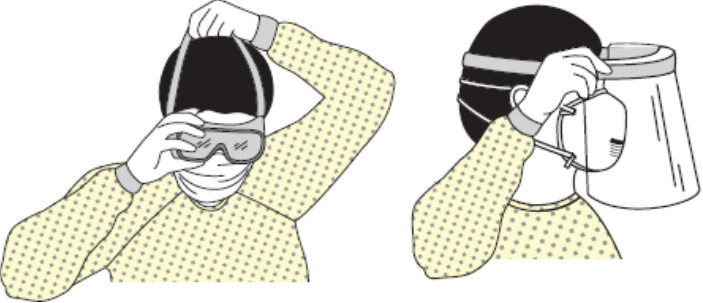
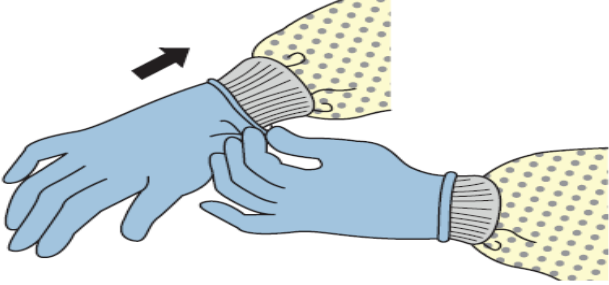
<p><b>GOWN</b></p> <ul style="list-style-type: none"> <li>• Fully cover torso from neck to knees, arms to end of wrists, and wrap around the back</li> <li>• Fasten in back of neck and waist</li> <li>• If the gown is with front opening, make sure to close the gown with appropriate button/zipper</li> </ul>	
<p><b>MASK OR RESPIRATOR</b></p> <p>Secure ties or elastic bands at middle of head and neck</p> <ul style="list-style-type: none"> <li>• Fit flexible band to nose bridge</li> <li>• Fit snug to face and below chin</li> <li>• Fit-check respirator <ul style="list-style-type: none"> <li>➢ Inhale – respirator should collapse</li> <li>➢ Exhale – check for leakage around face</li> </ul> </li> </ul>	
<p><b>GOGGLES OR FACE SHIELD</b></p> <ul style="list-style-type: none"> <li>• Position goggles over eyes and secure to the head using the ear pieces or headband</li> <li>• Position face shield over face and secure on brow with headband</li> <li>• Adjust to fit comfortably</li> </ul>	
<p><b>GLOVES</b></p> <ul style="list-style-type: none"> <li>• Do gloves last of all PPE</li> <li>• Select correct type and size</li> <li>• Check for any damage</li> <li>• Insert hands into gloves</li> <li>• Extend gloves over gown cuffs</li> </ul>	
<p><b>USE SAFE WORK PRACTICES TO PROTECT YOURSELF AND LIMIT THE SPREAD OF CONTAMINATION</b></p>	

## 2. Sequencing for Doffing/Removing Personnel Protective Equipment (PPE)

<p><b>GLOVES</b></p> <ul style="list-style-type: none"> <li>• Outside of gloves are contaminated!</li> <li>• If your hands get contaminated during glove removal, immediately wash your hands or use an alcohol-based hand sanitizer</li> <li>• Using a gloved hand, grasp the palm area of the other gloved hand and peel off first glove</li> <li>• Hold removed glove in gloved hand</li> <li>• Slide fingers of ungloved hand under remaining glove at wrist and peel off second glove over first glove</li> <li>• Discard gloves in a waste container</li> </ul>	
<p><b>GOWN</b></p> <ul style="list-style-type: none"> <li>• Gown front and sleeves are contaminated!</li> <li>• If your hands get contaminated during gown removal, immediately wash your hands or use an alcohol-based hand sanitizer</li> <li>• Unfasten gown ties, taking care that sleeves don't contact your body when reaching for ties</li> <li>• Pull gown away from neck and shoulders, touching inside of gown only</li> <li>• Turn gown inside out</li> <li>• Fold or roll into a bundle and discard in a waste container</li> </ul>	
<p><b>GOGGLES OR FACE SHIELD</b></p> <ul style="list-style-type: none"> <li>• Outside of goggles or face shield are contaminated!</li> <li>• If your hands get contaminated during goggle or face shield removal, immediately wash your hands or use an alcohol-based hand sanitizer</li> <li>• Remove goggles or face shield from the back by lifting head band or ear pieces</li> </ul> <p>If the item is reusable, place in designated receptacle for reprocessing. Otherwise, discard in a waste container</p>	
<p><b>MASK OR RESPIRATOR</b></p> <ul style="list-style-type: none"> <li>• Front of mask/respirator is contaminated – DO NOT TOUCH!</li> <li>• If your hands get contaminated during mask/respirator removal, immediately wash your hands or use an alcohol-based hand sanitizer</li> <li>• Grasp bottom ties or elastics of the mask/respirator, then the ones at the top, and remove without touching the front</li> <li>• Discard in a waste container</li> </ul>	
<p><b>WASH HANDS OR USE AN ALCOHOL-BASED HAND SANITIZER IMMEDIATELY AFTER REMOVING ALL PPE</b></p>	

## D. Annex 4: HIV Exposure Reporting Form

*Use this form to report and record an Occupational Blood and Needle Stick Exposure*

Laboratory / Department Name: \_\_\_\_\_

Name of Institution: \_\_\_\_\_

1. Exposed person's name: \_\_\_\_\_
2. Phone no.: \_\_\_\_\_
3. Age: \_\_\_\_\_ 4. Sex: \_\_\_\_\_
5. Incident date & time: \_\_\_\_\_
6. Location of exposure: \_\_\_\_\_

*(Please circle the appropriate letter in the following section)*

7. Type of injury
  - a. Hollow needle deep prick
  - b. Hollow needle superficial prick
  - c. Solid needle deep prick
  - d. Solid needle scratch
  - e. Splash to the conjunctivae
  - f. Splash to the oral cavity
  - g. Splash to intact skin
  - h. Splash to broken skin (specify): \_\_\_\_\_
  - i. Bite
8. Substance involved
  - a. Blood
  - b. Amniotic fluid
  - c. CSF
  - d. Body cavity fluid (specify): \_\_\_\_\_
  - e. Vaginal secretion
9. Did the body cavity fluid contain visible blood?
  - a. Yes
  - b. No
  - c. Not aware
10. Is the HIV status of the health care personnel (HCP) already known?
  - a. Yes (HCP is HIV+)
  - b. Yes (HCP is HIV-)
  - c. No (HCP's HIV status is unknown)
11. What is the HIV status of the source case?
  - a. Positive
  - b. Negative
  - c. Unknown
12. Circumstance of injury
  - a. When drawing blood from a patient
  - b. Needle stick injury during laboratory manipulation of blood (specify): \_\_\_\_\_
  - c. Needle stick while disposing of waste
  - d. Injury with broken glassware contaminated with blood or body fluids
  - e. Splash with body cavity fluids during procedure (specify): \_\_\_\_\_
  - f. Other (specify): \_\_\_\_\_
13. If the answer for question 11 is (c.), can the HIV status of the source case be determined?
  1. Yes
  2. No, because source case refused to be tested
  3. Other (specify): \_\_\_\_\_
14. Additional questions

## E. Annex 5: Incident Report Form

Use this form to report accidents, injuries, medical situations, and any incidents. If possible, the report should be completed immediately and reported to the supervisor.

INFORMATION ABOUT THE INCIDENT		
Date of Incident	Time	Police Notified <input type="checkbox"/> Yes <input type="checkbox"/> No
Location of Incident		
Description of Incident (what happened, how it happened, factors leading to the event, etc.) Be as specific as possible (attached additional sheets if necessary)		
Were there any witnesses to the incident? <input type="checkbox"/> Yes <input type="checkbox"/> No If yes, attach separate sheet with names, addresses, and phone numbers.		
Was the individual injured? If so, describe the injury (laceration, sprain, etc.), the part of body injured, and any other information known about the resulting injury(ies)		

Reported by \_\_\_\_\_ Sign. \_\_\_\_\_ Date \_\_\_\_\_

## **F. Annex 5: General Description of Biological Agents/Materials**

### **i. Overview of Biological Agent/Material**

Biological material refers to microorganisms, proteins, and nucleic acids, or anything that contains them (e.g., tissue) whether or not they are infectious or toxic. Pathogens are a subset of biological material that is capable of causing disease in humans or animals. WHO also defines that Biological agents are A microorganism, virus, biological toxin, particle or otherwise infectious material, either naturally occurring or genetically modified, which may have the potential to cause infection, allergy, toxicity or otherwise create a hazard to humans, animals, or plants.

The term "infectious material" is used throughout to collectively refer to pure cultures or isolates of pathogens as well as any material that may contain a pathogen (e.g., infected tissue sample) or part of one that retains its pathogenicity. A microbial toxin that is isolated from its parental organism or synthetically produced is not infectious by nature; therefore, toxins are not included in the term "infectious material". This chapter provides a brief overview of the basic characteristics of the various types of biological material that are important in the context of the Ethiopia

### **ii. Bacteria**

Bacteria are single-celled prokaryotic organisms lacking a nucleus and other membrane-enclosed organelles.

Some bacteria can induce an immune response (e.g., inflammation) in a host organism, secrete exotoxins, produce surface-associated endotoxins, or form spores that enhance survival and transmission outside of the host for extended periods of time. Bacteria that can infect and cause disease in humans or animals are referred to as pathogenic bacteria. Some bacteria are opportunistic pathogens that can colonize the body of a human or animal host and may not cause disease unless a disruption occurs in the host's immune system or natural barriers to infection (i.e., immunocompromised or immunosuppressed), or if the host is exposed to a high dose of the pathogen. In comparison, obligate pathogenic bacteria cannot survive outside of a host and must cause disease in order to survive and be transmitted from one host to another. Examples of pathogenic bacteria include *Bacillus anthracis*, certain strains of *Escherichia coli*, *Mycobacterium tuberculosis*, and *Salmonella* species (spp.).

### **iii. Viruses**

Viruses are the smallest of replicating organisms. Their small size (20-300 nm) allows them to pass through filters that typically capture the smallest bacteria. Viruses have no metabolism of their own and redirect

existing host machinery and metabolic functions to replicate. Structurally, the simplest viruses consist of nucleic acids enclosed in a protein capsid (nucleocapsid). Enveloped viruses have a more complex structure in which the nucleocapsid is enclosed inside a lipid bilayer membrane; this membrane facilitates the virus's interaction with the host cell.

Viruses are classified by their replication strategy and by the organization of their genome (i.e., double-stranded deoxyribonucleic acid [DNA], single-stranded DNA, reverse transcribing, double-stranded ribonucleic acid [RNA], negative-sense single-stranded RNA, positive-sense single-stranded RNA, and subviral agents). There are many virus families that are able to infect human or animal hosts. Some are species-specific while others infect a wide range of host species. Some viruses are able to produce a persistent infection (i.e., host cell remains alive and continues to produce virus particles over a long period of time) or a latent infection (i.e., there is a delay of months or years between infection and the appearance of disease symptoms), or they may alter the host genome by integrating (e.g., integration of a retrovirus into the host genome). Examples of pathogenic viruses include influenza virus, human immunodeficiency virus (HIV), herpes virus, rabies virus, and Ebola virus.

#### **iv. Fungi**

Fungi are eukaryotic microorganisms that can be easily distinguished from bacteria and other prokaryotes by their greater size and the presence of organelles; including a nucleus, vacuoles, and mitochondria. Yeast normally grow as single cells, whereas moulds grow in branching chains. Of the 1.5 million estimated fungal species, over 500 are known to cause disease in human or animal hosts, including several species of yeast and moulds.

Exposure to fungal spores can occur via the airborne route, inoculation, or close contact, depending on the species. In addition, some fungal species may produce and disperse mycotoxins (toxins are further described). In general, human and animal tissues, including blood, are not considered a risk for the airborne dispersal of fungal spores. Most species of fungi are opportunistic pathogens and will generally only cause disease in immunocompromised individuals. Examples of pathogenic fungi include *Aspergillus fumigatus*, *Candida albicans*, *Blastomyces dermatitidis*, and *Histoplasma capsulatum*.

#### **v. Parasites**

Protozoa and helminths are parasites that live on or within a larger host organism at the host's expense.<sup>8</sup> Protozoa are single-celled eukaryotic microorganisms that lack a cell wall and are generally motile.

Helminths are eukaryotic worms that may grow large enough to be visible to the naked eye. Parasites that live within the tissues or cells of their host are known as endoparasites and cause infections that are generally treatable. Some endoparasites can persist for many years in the human body, even following treatment, and will re-surface to cause disease if the host becomes immunocompromised. Ectoparasites live on the external surface, or within the skin of their host, causing an infestation. The type and degree of injury inflicted on the host will vary based on the number of parasites present.

While most helminths in the adult stage of their life-cycle may be quite large and easily visible to the naked eye, they are generally only infectious during life-cycle phases in which they are very small (e.g., egg, larval stage). Since helminths in their infectious stage can be transmitted by ingestion, direct contact, injection, and inhalation, they present a risk similar to that of other microorganisms for accidental or unintentional exposure. Examples of pathogenic protozoa include *Plasmodium falciparum*, *Leishmania donovani*, *Cryptosporidium parvum*, *Giardia lamblia*, and *Trypanosoma cruzi*. Examples of pathogenic helminths include *Trichinella spiralis* (nematode), *Enterobius vermicularis* (pinworm), and *Hymenolepis nana* (tapeworm).

#### vi. Prions

**Prions** are small, proteinaceous infectious particles that are generally accepted to be the cause of a group of progressive neurodegenerative diseases in humans and animals known as **transmissible spongiform encephalopathies (TSEs)**. When an infectious prion enters a host, it induces the normally folded prion protein to convert to the disease-associated, misfolded prion isoform. The pathogenic isoform acts as a template that guides the misfolding of more prion proteins, eventually leading to the accumulation of large amounts of the extremely stable, misfolded proteins in infected tissue, causing tissue damage and cell death.

Prion proteins are extremely heat stable, able to bind with high affinity to metal surfaces, and can persist for long periods in the natural environment. The most likely route of transmission to personnel handling infectious prions is through accidental inoculation or ingestion of infected tissues. TSEs are unique due to the long incubation times (up to 30 years) before disease symptoms appear. Examples of TSEs in animals include bovine spongiform encephalopathy (BSE), scrapie, and chronic wasting disease (CWD). Examples of TSEs in humans include Creutzfeldt-Jakob disease (CJD), variant Creutzfeldt-Jakob disease (vCJD), Gerstmann-Straussler-Scheinker syndrome, fatal familial insomnia, and kuru. Some prions are zoonotic pathogens, such as the BSE prions.

## vii. Zoonotic Pathogens

The term "**zoonoses**" describes diseases that are transmissible between animals and humans; it encompasses both anthroozoonoses (i.e., diseases transmitted from animals to humans), and zooanthroponoses or "reverse zoonoses" (i.e., diseases transmitted from humans to animals). There have been several documented laboratory acquired infections (LAIs) involving zoonotic pathogens transmitted to humans by an animal infected with or carrying a zoonotic pathogen. The risk of zoonosis exists in activities involving animals experimentally infected with a zoonotic pathogen, as well as in activities involving first generation wild-caught animals that may be infected with or carrying a pathogen indigenous to the animal's natural environment. For example, Macacine herpesvirus 1 (formerly known as herpes B virus or cercopithecine herpes virus 1) is an **enzootic** virus present in up to 70% of captive macaques, including rhesus macaques and cynomolgus monkeys, and has been associated with at least 50 documented LAIs. Documented zoonoses in humans have been caused by bacteria (e.g., *Salmonella* spp. can cause salmonellosis; *Yersinia pestis* can cause plague), viruses (e.g., rabies virus can cause rabies), parasites (e.g., *Toxoplasma gondii* can cause toxoplasmosis), and prions (e.g., BSE agent can cause vCJD).

## viii. Toxins

Microbial toxins are poisonous substances that are a natural product of the metabolic activities of certain microorganisms (e.g., bacteria, fungi). Toxins can cause adverse health effects, known as **intoxication**, which can include asymptomatic or symptomatic physiological changes, severe incapacitation, or death in a human or animal resulting from an exposure (i.e., ingestion, inhalation, inoculation, or absorption) to a toxin. Severe health effects may even occur in response to relatively low dose exposures of toxins. Toxins do not replicate and are not transmitted from person to person. The most likely route of transmission to personnel handling toxins is through accidental inoculation or by the exposure of mucous membranes to aerosolized toxins. Some toxins can be artificially produced by chemical synthesis or by recombinant DNA (rDNA) technology (rDNA technology is further described in Section 2.8.1). Microbial toxins are classified according to the organism from which the toxin is derived (e.g., bacterial, fungal). Microbial intoxication is typically associated with bacteria.

Two types of microbial toxins exist: exotoxins and endotoxins. Exotoxins are often heat-labile proteins and polypeptides that are produced and secreted by a variety of species, including both Gram-negative and Gram-positive bacteria. Bacterial exotoxins can exert their toxic effects on the host through the following five mechanisms: damage to cell membranes, inhibition of protein synthesis, inhibition of neurotransmitter



release, activation of secondary messenger pathways, or activation of host immune responses. Examples of exotoxins include tetanus toxin, produced by the Gram-positive bacterium *Clostridium tetani*, and cholera toxin, produced by the Gram-negative bacterium *Vibrio cholerae*. Additionally, a family of heat-stable exotoxins exists, called enterotoxins, which exert their primary effects on the digestive tract. Some examples include Staphylococcus Enterotoxin Type B produced by *Staphylococcus aureus*, heat-stable enterotoxins produced by enterotoxigenic *Escherichia coli* (ETEC), and cereulide produced by *Bacillus cereus*. Endotoxins are structural molecules (i.e., lipopolysaccharides or lipooligosaccharides) that are embedded in the outer membrane of the cell wall of certain Gram-negative bacteria, such as *Escherichia coli* and *Shigella dysenteriae*. Endotoxins are relatively heat-stable and generally less toxic than exotoxins.

A subset of microbial toxins is regulated by the Public Health Agency of Canada (PHAC) and the CFIA under the HPTA, *Human Pathogens and Toxins Regulations* (HPTR), *Health of Animals Act* (HAA), and *Health of Animals Regulations* (HAR); an exhaustive list of regulated toxins affecting humans can be found in Schedules 1 and 5 of the HPTA.

#### **ix. Genetically Modified Organisms**

Genetically Modified Organisms (GMOs) are organisms (i.e., plants, animals, or microorganisms) that are created through the alteration of genetic materials in a way that does not occur naturally through mating or natural recombination. The best known method for creating GMOs is through the application of rDNA technologies. A GMO can be as simple as a point-mutated bacteria strain (e.g., *E. coli* DH5-Alpha) or rDNA cloned into a viral host (e.g., vaccinia virus vaccines) to overexpress a specific gene for further study. More complex GMOs include transgenic and knock-out animals (e.g., severe combined immunodeficiency mice) whose genome has been altered by the insertion, removal, or alteration of DNA segments.



ጤና ሚኒስቴር - ኢትዮጵያ  
MINISTRY OF HEALTH - ETHIOPIA



**Ethiopian Public Health Institute**  
Addis Ababa, Ethiopia



+251 11 213 3499



info@ephi.gov.et



<https://ephi.gov.et>